

FY2016 1st Half Results and Annual Forecasts

SUMITOMO ELECTRIC INDUSTRIES, LTD.

2016/11/17

INDEX

1. FY2016 1st Half Results

1. FY2016 1st Half Results(PL)
2. Factors of Increase or Decrease in OP
3. Sales and OP by Segment
4. Overseas Sales Ratio
5. FY2016 1st Half BS

2. FY2016 Forecasts

1. FY2016 Forecasts(PL)
2. Sales and OP by Segment
3. FY2016 Challenges and Strategies
4. Capital Investment by Region/Segment
5. R&D by Segment

3. Increase in Production Capacity of Optical & Electron Devices

1. Optical & Electron Device Products
2. Remarkable Optical Device Products
3. Remarkable Electron Device Products

4. Dividend

1. FY2016 1st Half Results

1-1. FY2016 1st Half Results(PL)

Sales, OP and ordinary income all decreased as compared with the same period of the previous year and did not reach the plan, mainly due to forex loss and copper price decline.

	FY2015 1H Actual①	FY2016 1H Plan②	FY2016 1H Actual③	Growth ③ - ①	Difference ③ - ②
Net Sales	1,439.4	1,400.0	1,312.1	(127.3)	(87.9)
Operating Profit	52.9	55.0	47.1	(5.8)	(7.9)
Non-Operating Income/Expense	9.3	10.0	14.1	+4.8	+4.1
Ordinary Income	62.2	65.0	61.2	(1.0)	(3.8)
Gain on Sales of Investment Securities	3.0		5.6	+2.6	
Restructuring Expenses	(1.3)		(2.2)	(0.9)	
Settlement	(2.6)		(8.8)	(6.2)	
Extraordinary Others	(1.8)	(25.0)	(1.4)	+0.4	+2.7
Income before Income Taxes	59.5		54.4	(5.1)	
Net Income Attributable to Non-Controlling Interests	(23.7)		(15.5)	+8.2	
Net Income Attributable to Owners of Parent	35.8	40.0	38.9	+3.1	(1.1)

1-2. Factors of Increase or Decrease in OP

OP decreased by ¥5.8bn mainly due to forex loss, despite sales volume increase and cost reduction efforts.

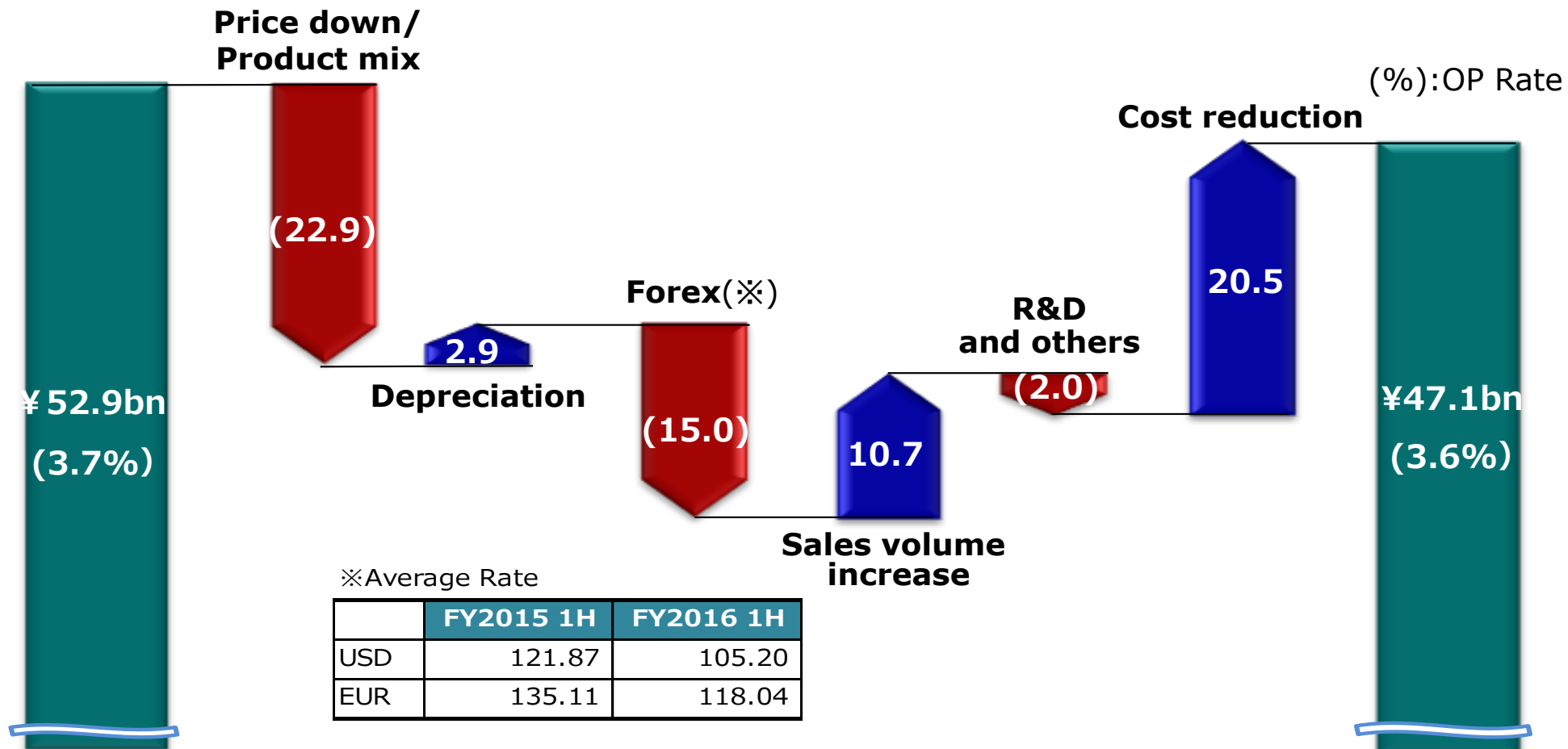

FY2015 1H
Actual

FY2016 1H
Actual

1-3. Sales and OP by Segment

Whereas Automotive achieved record high OP and OP of Infocommunications increased as compared with the same period of the previous year and the plan, both sales and OP of Electronics decreased due to downturn of FPC.

	FY2015 1H		FY2016 1H		FY2016 1H		Growth		Difference	
	Actual ①		Plan ②		Actual ③		③-①		③-②	
	¥ bn	Sales	OP	Sales	OP	Sales	OP	Sales	OP	Sales
Automotive	765.5	37.1	730.0	38.0	719.2	38.3	(46.3)	+1.2	(10.8)	+0.3
Infocommunications	84.2	1.8	90.0	0.0	90.0	4.5	+5.8	+2.7	+0.0	+4.5
Electronics	163.7	7.0	140.0	4.0	118.0	(7.3)	(45.7)	(14.3)	(22.0)	(11.3)
Environment and Energy	308.5	(0.7)	310.0	2.0	277.9	1.8	(30.6)	+2.5	(32.1)	(0.2)
Industrial Materials and Others	157.3	7.9	150.0	11.0	143.0	9.8	(14.3)	+1.9	(7.0)	(1.2)
Total	1,439.4	52.9	1,400.0	55.0	1,312.1	47.1	(127.3)	(5.8)	(87.9)	(7.9)

※ Differences between the aggregate of all segments and Total are eliminations.

1-4. Overseas Sales Ratio

Sales(M\$)

Ratio(%)

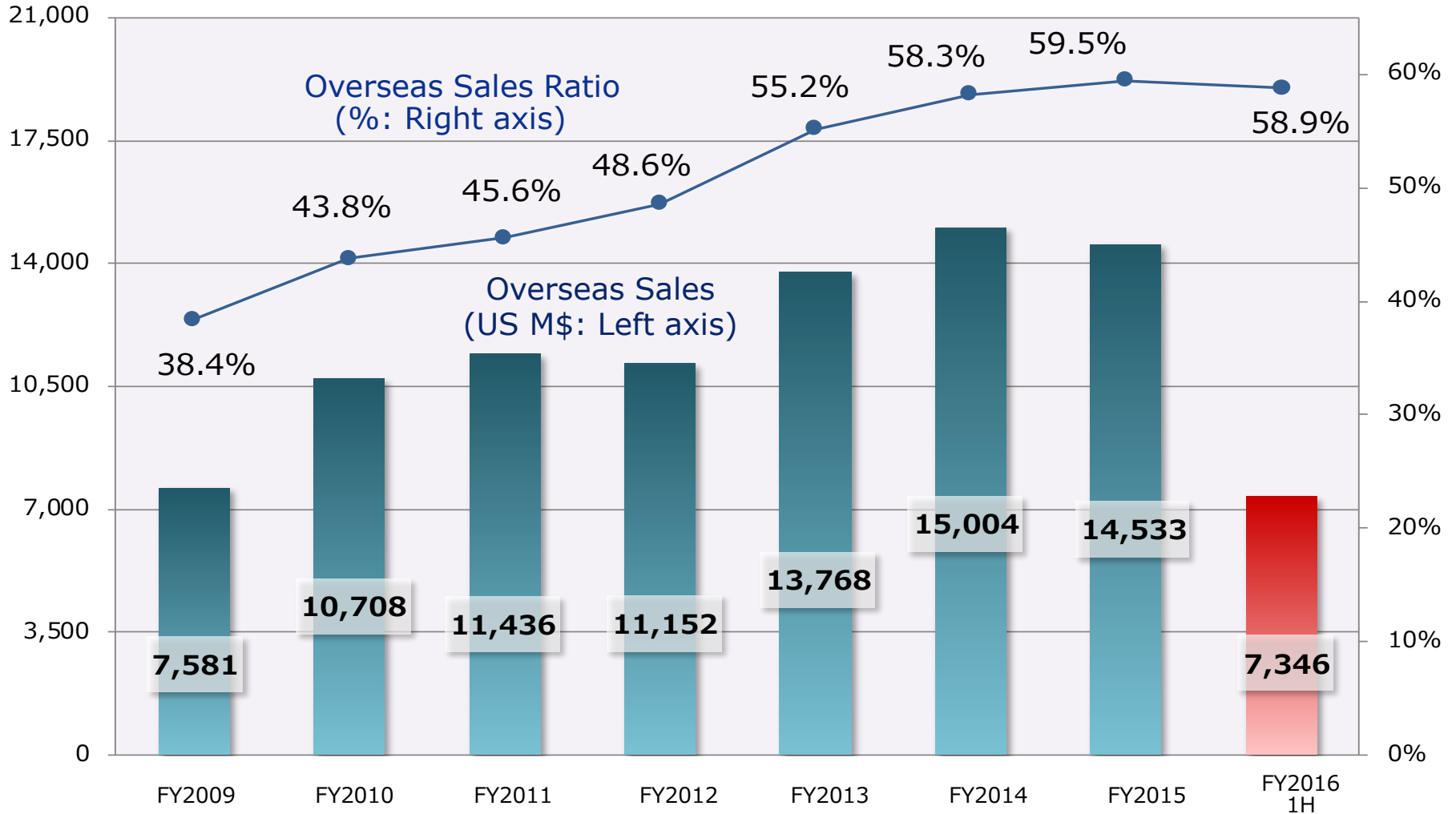

1-5. FY2016 1st Half BS

¥ bn	FY2014 Actual	FY2015 Actual	FY2016 1H Actual	
Current Assets	1,415.6	1,357.2	1,307.0	
Non-Current Assets	1,510.2	1,385.6	1,370.8	
Current Liabilities	809.9	771.2	764.1	
Non-Current Liabilities	469.0	410.4	435.8	
(Interest Bearing Debt)	(550.8)	(457.2)	(508.3)	
Shareholders' Equity	1,191.0	1,251.7	1,255.9	
Accumulated Other Comprehensive Income	240.2	108.8	32.8	
Non- Controlling Interests	215.7	200.7	189.2	
Total Assets	2,925.8	2,742.8	2,677.8	
Shareholders' Equity Ratio	48.9%	49.6%	48.1%	
Debt/Equity Ratio	0.38	0.34	0.39	
	FY2014 Actual	FY2015 Actual	FY2016 Revised Plan	FY2016 Original Plan
Operating Income / Invested Assets(ROA)※	6.5%	6.8%	6.2%	7.8%
Return on Equity(ROE)	9.1%	6.5%	6.4%	7.3%

※Operating Income / Invested Assets(ROA) = $\frac{\text{Operating Income}}{\text{Total Assets} - \text{Interest-Free Liabilities}}$

2. FY2016 Forecasts

2-1. FY2016 Forecasts(PL)

FY2016 original forecasts were revised downward due to forex loss, copper price decline and FPC downturn, although Automotive and Infocommunications would be performed steadily.

¥ bn	FY2015 Actual ①	FY2016 Original Plan			FY2016 Revised Plan			Growth ③ - ①	Difference ③ - ②
		1H Plan	2H Plan	Annual Plan②	1H Actual	2H Plan	Annual Plan③		
		Forex Rate (Original Plan) ¥110/USD ¥125/EUR			Forex Rate (1H Actual) ¥105.20/USD ¥118.04/EUR		Forex Rate (2H Plan) ¥100/USD ¥110/EUR		
Net Sales	2,933.1	1,400.0	1,550.0	2,950.0	1,312.1	1,487.9	2,800.0	(133.1)	(150.0)
Operating Profit	143.5	55.0	105.0	160.0	47.1	77.9	125.0	(18.5)	(35.0)
Non-Operating Income/Expense	22.2	10.0	15.0	25.0	14.1	10.9	25.0	+2.8	+0.0
Ordinary Income	165.7	65.0	120.0	185.0	61.2	88.8	150.0	(15.7)	(35.0)
Net Extraordinary Income/Loss	(10.8)				(68.0)				
Income before Income Taxes	154.9	(25.0)	(60.0)	(85.0)	54.4	(42.7)	(65.0)	+9.7	+20.0
Net Income Attributable to Non-Controlling Interests	(63.9)				(15.5)				
Net Income Attributable to Owners of Parent	91.0	40.0	60.0	100.0	38.9	46.1	85.0	(6.0)	(15.0)

2-2. Sales and OP by Segment

¥ bn	FY2016 Original Plan				FY2016 Revised Plan				Difference	
	1H Plan		Annual Plan		1H Actual		Annual Plan		Sales	OP
	Sales	OP	Sales	OP	Sales	OP	Sales	OP		
Automotive	730.0	38.0	1,480.0	89.0	719.2	38.3	1,440.0	82.0	(40.0)	(7.0)
Infocommunications	90.0	0.0	210.0	13.0	90.0	4.5	220.0	16.0	+10.0	+3.0
Electronics	140.0	4.0	310.0	12.0	118.0	(7.3)	250.0	(14.0)	(60.0)	(26.0)
Environment and Energy	310.0	2.0	690.0	21.0	277.9	1.8	630.0	19.0	(60.0)	(2.0)
Industrial Materials and Others	150.0	11.0	320.0	25.0	143.0	9.8	310.0	22.0	(10.0)	(3.0)
Total	1,400.0	55.0	2,950.0	160.0	1,312.1	47.1	2,800.0	125.0	(150.0)	(35.0)

※Differences between the aggregate of all segments and Total are eliminations.

2-3. FY2016 Challenges and Strategies(1)

Automotive

¥bn	FY2016 Original Plan		FY2016 Revised Plan		Difference	
	1H	Annual	1H Actual	Annual	1H	Annual
Operating Profit	38.0	89.0	38.3	82.0	+0.3	(7.0)

- **Expansion of revenue sources** (Development and sales promotion of high value added products such as aluminum harnesses, connectors/components and others)
- **Improvement of global cost competitiveness** (Material cost reduction, optimization of global production allocation, manpower saving)
- Global development of sales promotion and profitability by **acceleration of synergistic effect of the companies purchased by Sumitomo Riko**

Infocommunications

¥bn	FY2016 Original Plan		FY2016 Revised Plan		Difference	
	1H	Annual	1H Actual	Annual	1H	Annual
Operating Profit	0.0	13.0	4.5	16.0	+4.5	+3.0

- **Acceleration of global deployment**(Coping with high demand in China and North America, etc.)
- **Strengthening high value added new products**(GaN device for mobile base station, 100G optical device, optical fiber for submarine cable, ultra high count fiber cable for data center, etc.)

Electronics

¥bn	FY2016 Original Plan		FY2016 Revised Plan		Difference	
	1H	Annual	1H Actual	Annual	1H	Annual
Operating Profit	4.0	12.0	(7.3)	(14.0)	(11.3)	(26.0)

- **Reinforcement of global production base** for FPC (global quality control and cost reduction)
- Establishment of optimized portfolio by **customer and product frontage expansion**
- **Acceleration of development of new products** (Ultra-thin, fine pitch and high heat resistant FPC)

2-3. FY2016 Challenges and Strategies(2)

Environment and Energy

¥bn	FY2016 Original Plan		FY2016 Revised Plan		Difference	
	1H	Annual	1H Actual	Annual	1H	Annual
Operating Profit	2.0	21.0	1.8	19.0	(0.2)	(2.0)

- **Speedup of strengthening constitution of Power cable business**
 - Sales promotion to meet high demand in overseas submarine power cable market and **sure execution of large projects** already on hand without delay
 - Establishment of production system to **increase production capacity** and **enhance competitiveness in cost and quality**
- Business expansion in new energy and smart grid markets **in coordination with Sumitomo Densetsu and Nissin Electric**
- **Acceleration of development and demonstration in both domestic and overseas** for new energy system related products (Redox flow battery, sCPV system, etc.)

Industrial Materials and Others

¥bn	FY2016 Original Plan		FY2016 Revised Plan		Difference	
	1H	Annual	1H Actual	Annual	1H	Annual
Operating Profit	11.0	25.0	9.8	22.0	(1.2)	(3.0)

- **Acceleration of global deployment** for Sintered parts (utilization of purchased US company)
- **Establishment of new business model** in which material is core
(Hard metal : Sales promotion to **aircraft**, precision processing and **emerging markets** such as China, Taiwan, India, etc.
A.L.M.T. : Intensive cost reduction, **concentration of resources in growing area**)

2-4. Capital Investment by Region/Segment

Capital investment in FY2016 is planned to be ¥190bn in total.

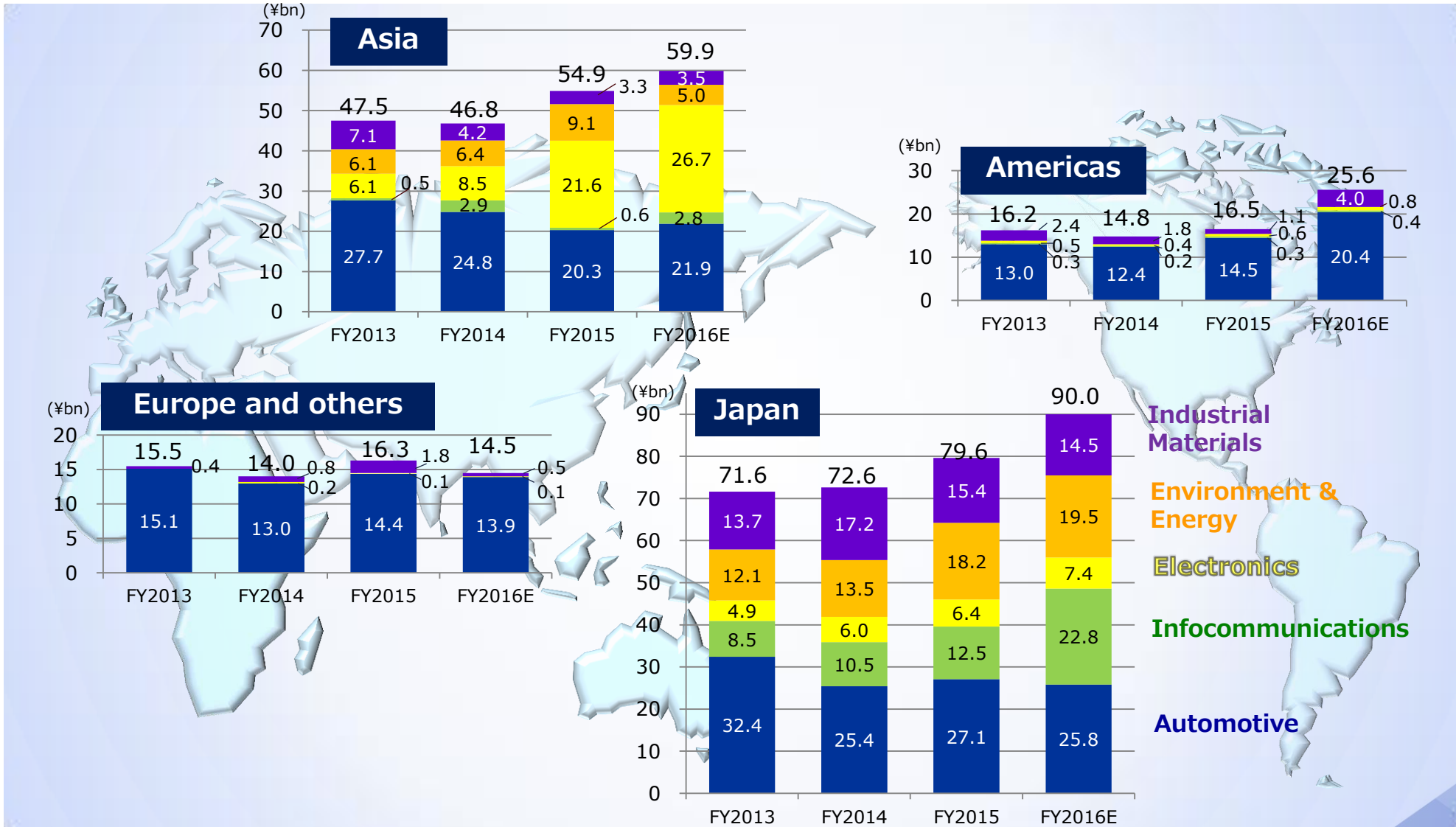

2-5. R&D by Segment

R&D expenses in FY2016 are estimated to be ¥110bn, which is the same level as the last year's record high

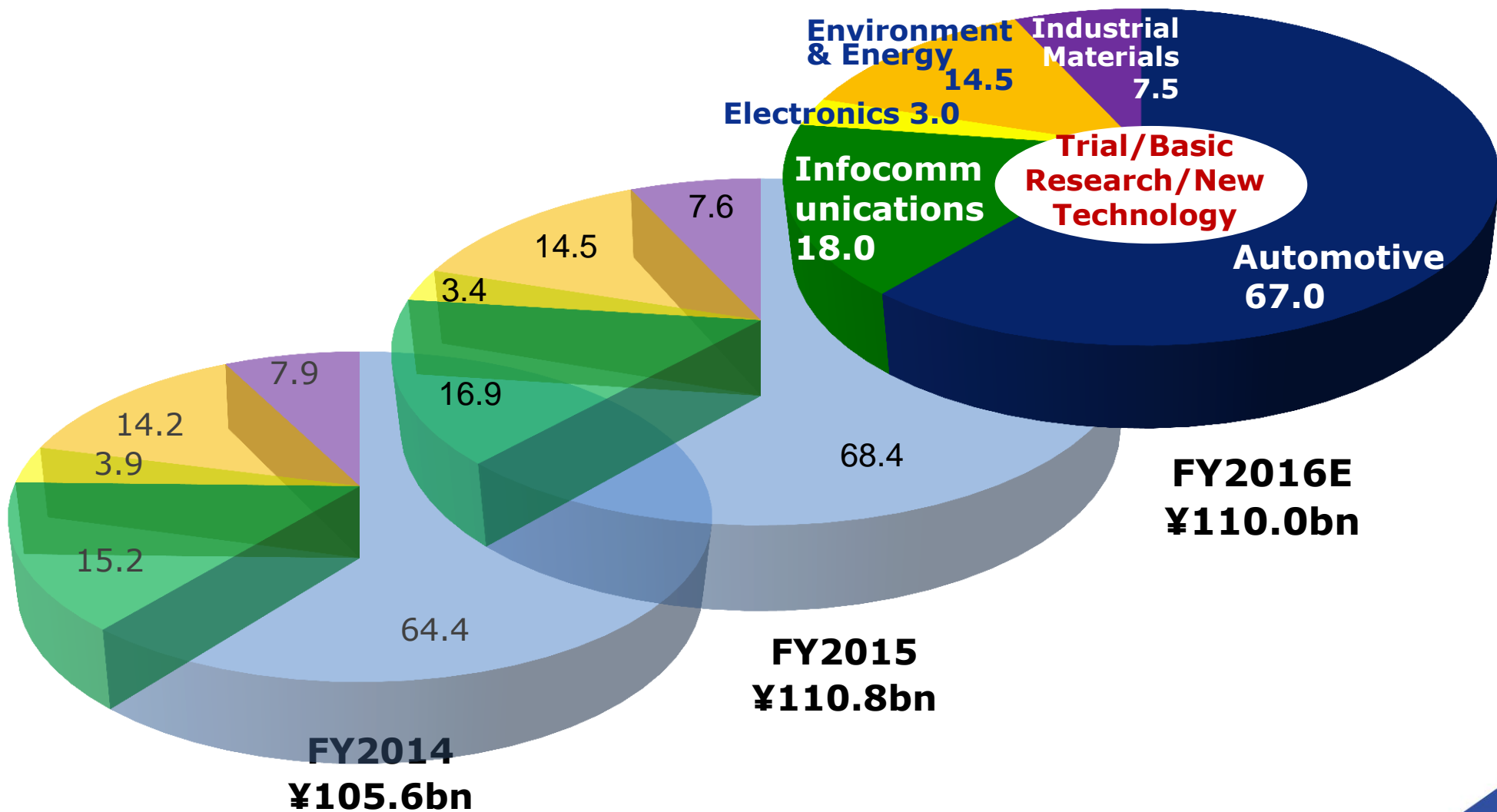

3. Increase in Production Capacity of Optical & Electron Devices

3-1. Optical & Electron Device Products

➤ Product Line-up Strategy

Coherent Optical Device

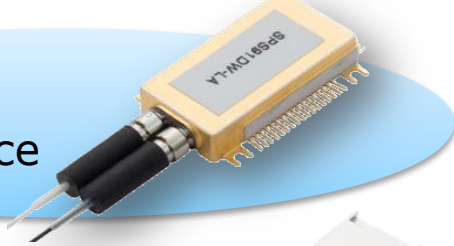

Optical Transceiver

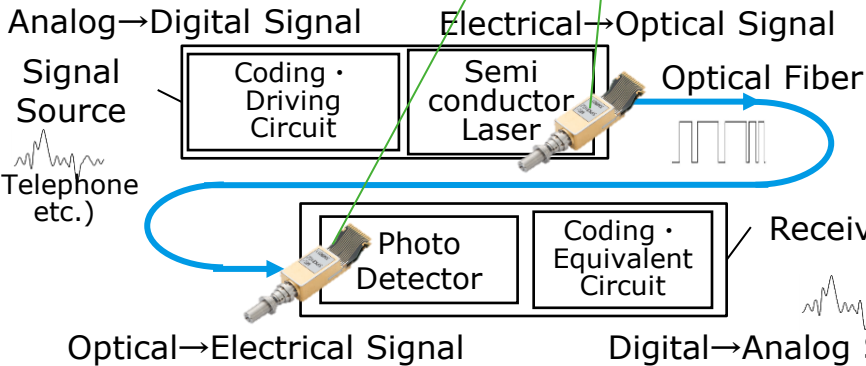
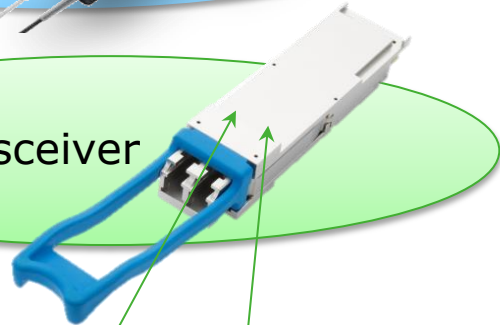

Electron Device

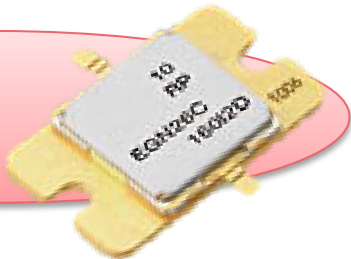

Trunk Line 600km or more
Long Range, Inter-Continental Optical Network

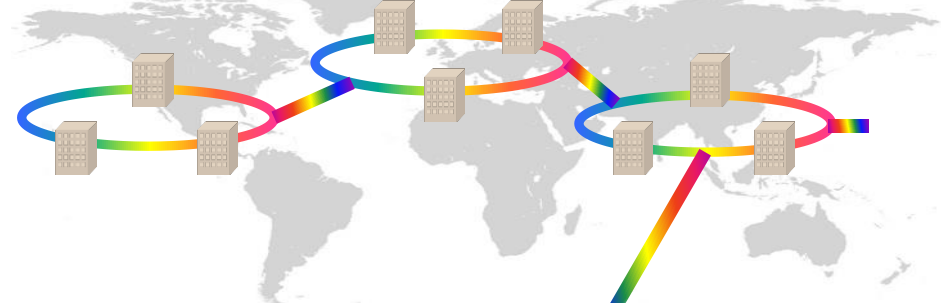

Client 10-40km
Medium Range, Inter-City Optical Network

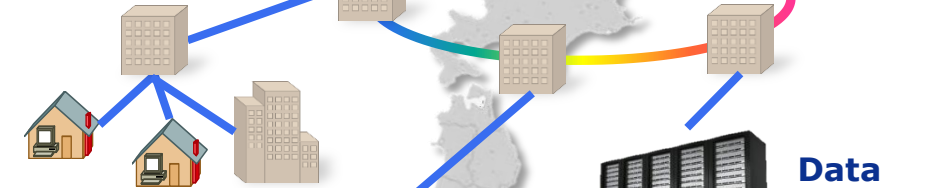

Access
FTTH, CATV

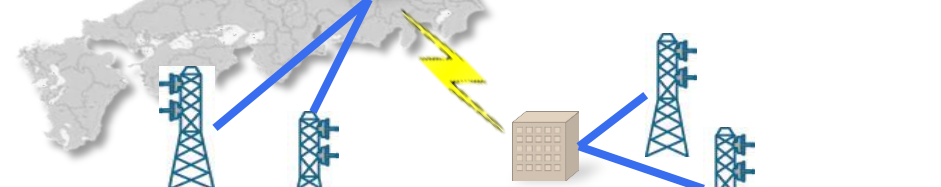

Mobile
4G LTE
Cellular Base Station



Multiple Wavelength Network
Single Wavelength Network

3-2. Remarkable Optical Device Products

➤ Coherent Optical Device

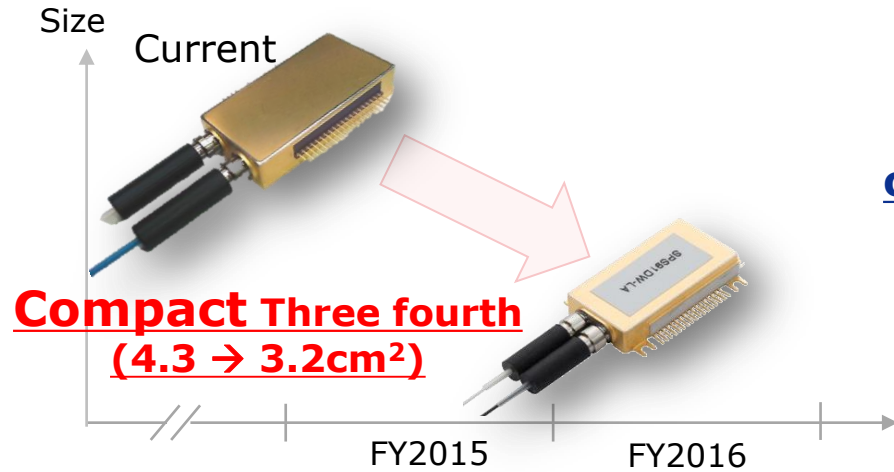

➤ Optical Transceiver, Optical Device

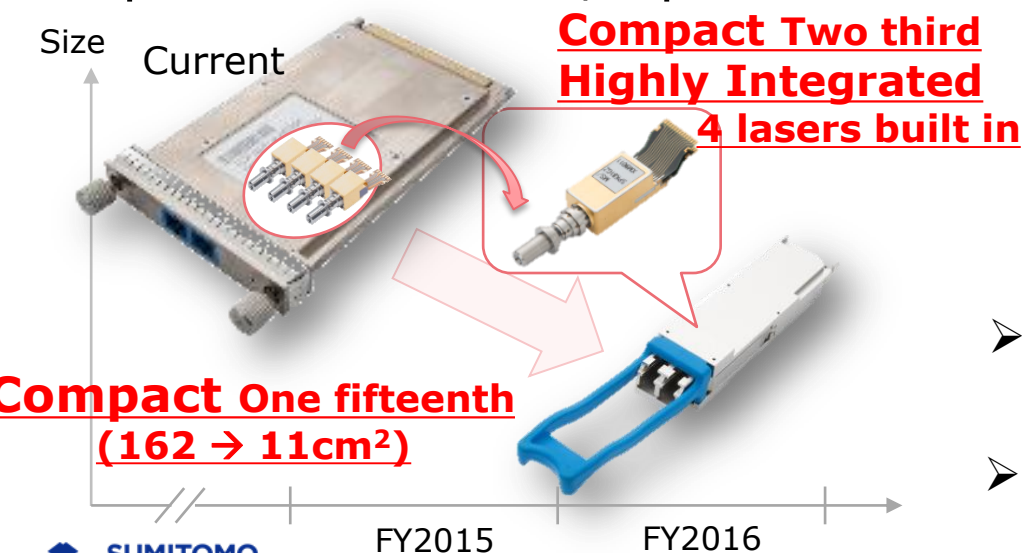

Production Capacity of Remarkable Product (Compared with FY2014)

Optical Device, Transceiver Total

**Mass Production Started Ahead
of Competitors thru World's Top
Compact & Highly Integrated
Technology**

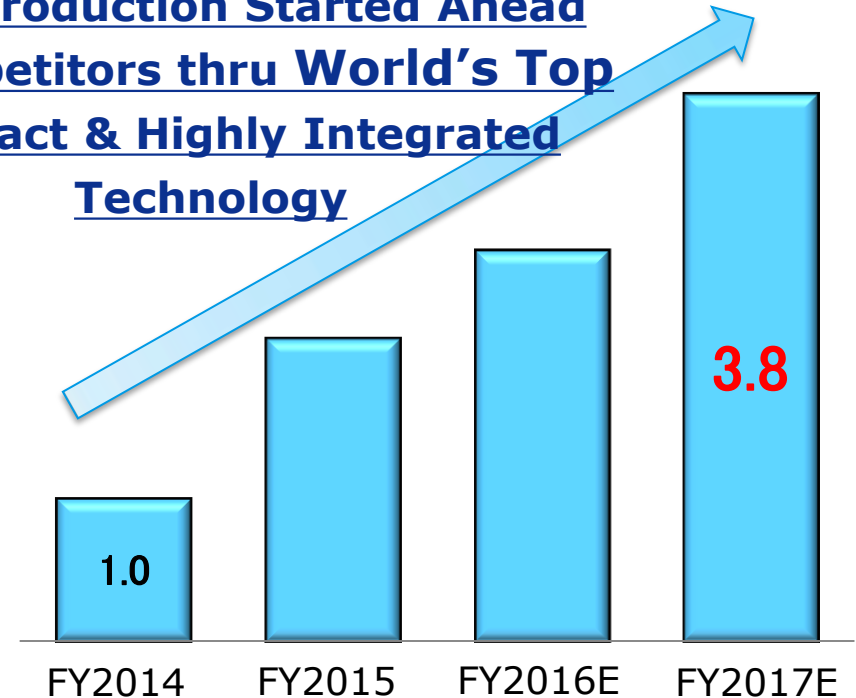

- 100Gbps Optical Transceiver Global Share **No.1** (FY2015)
- Developing **400Gbps** Optical Device for Next Generation High Speed Communication (Late 2017~)

3-3. Remarkable Electron Device Products

- Electron Device for Amplifier for 4G Cellular Base Station

Gallium Nitride (GaN) Transistor

Power Saving 10%*

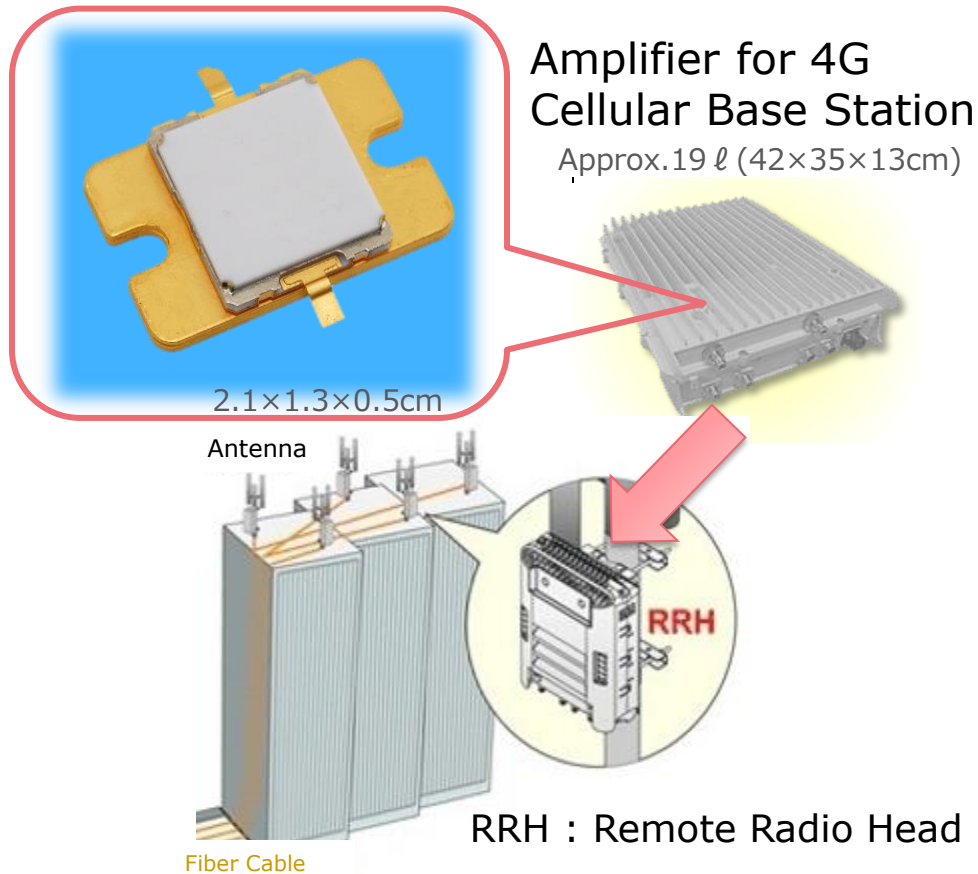

Production Capacity of Remarkable Product
(Compared with FY2014)

GaN Transistor for Cellular Base Station Share No.1

(FY2015)

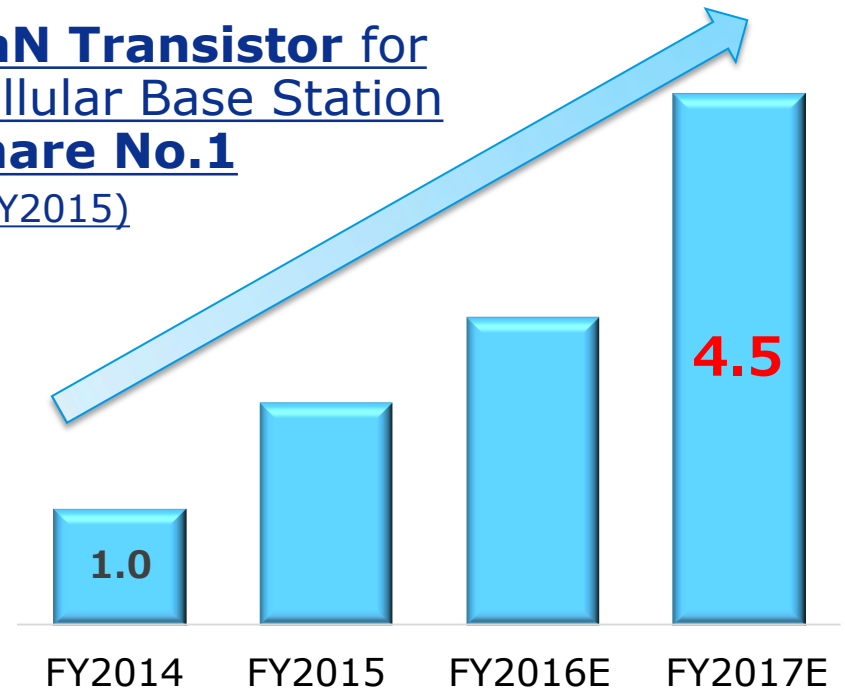

- SEI GaN Transistor Won **Technology Management & Innovation Award** of Japan Techno-Economics Society (2014)

- Developing GaN Products for **5G** Cellular Communication (around 2020~)

*Compared with 3.5GHz Si device (SEI research)

4. Dividend

4. Dividend

FY2016 annual dividend is planned to be ¥35/share, the same amount as the original plan.

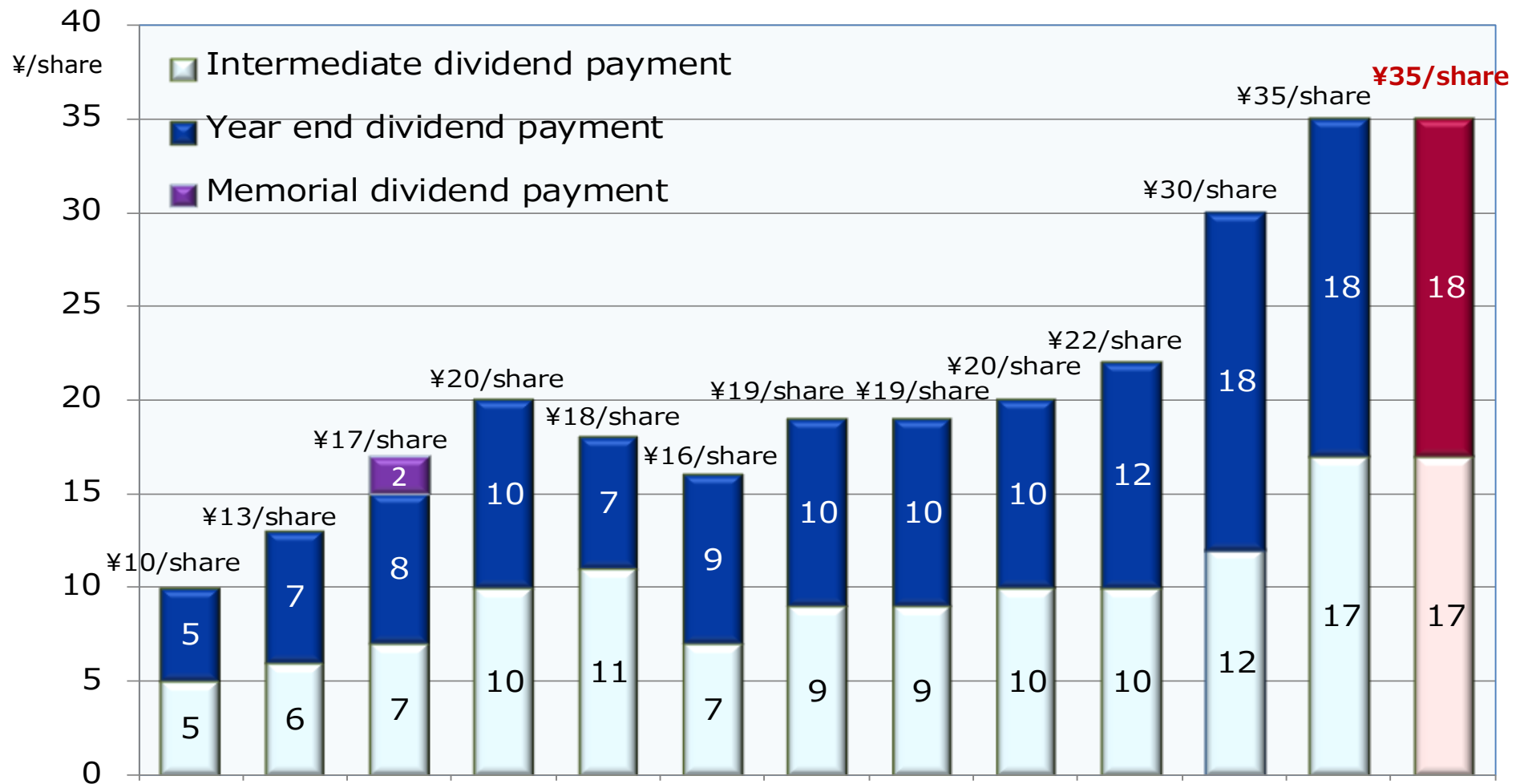

Net Income per Share (Yen)
Dividend Payout Ratio

Fiscal Year	FY2004	FY2005	FY2006	FY2007	FY2008	FY2009	FY2010	FY2011	FY2012	FY2013	FY2014	FY2015	FY2016E
Net Income per Share (Yen)	48.01	76.43	100.22	112.74	21.78	36.19	89.02	74.21	47.85	84.15	151.00	114.73	108.74
Dividend Payout Ratio	20.8%	17.0%	17.0%	17.7%	82.6%	44.2%	21.3%	25.6%	41.8%	26.1%	19.9%	30.5%	32.2%

Notes on Perspective Information

This presentation material contains various outlook and perspective information derived from our own presumptions and judgments based on currently available information on conditions and prospects of each market and economic circumstances such as currency exchange rate fluctuations. All figures and statements with respect to the future performances, projections, and business plans of Sumitomo Electric and its affiliated companies are constituted by those outlook and perspective information. Factors that could cause actual results to differ materially include, but not limited to:

1. Market and economic conditions in the United States, Europe, Japan and other Asian countries, especially increases and decreases in personal consumption and capital expenditures.
2. Fluctuations of currency exchange rates, especially between the Japanese yen and the U.S. dollar, the euro and Asian currencies.
3. The ability of Sumitomo Electric and its affiliated companies to cope with rapid technological development.
4. Changes in financial, management, environmental and other presumptions.
5. Current and future laws and regulations in foreign countries involving trade and other activities.
6. Changes in the market value of securities owned by Sumitomo Electric and its affiliated companies.

There are possibilities that actual sales and profits may be different materially from those described in this material. Sumitomo Electric and its affiliated companies are not obliged to update or make public any future performances, projections or business plans after releasing this material.