

Current rating

Nominal cross-section mm ²	Current rating A			
	Single core	2 core	3 core	4 core
0.75	18	15	13	12
1.25	25	21	18	16
2	32	27	23	21
3.5	47	39	33	30
5.5	62	51	44	40
8	77	63	54	49
14	105	89	76	69
22	145	120	100	93
38	205	165	140	125
60	280	220	185	170
100	390	310	265	240
150	528	408	348	—
200	619	470	400	—
250	695	—	—	—
325	820	—	—	—

Rating factor for ambient temp.

Ambient temp. °C	Rating factor
30	1.00
35	0.95
40	0.89
45	0.84
50	0.77
55	0.71
60	0.65
65	0.54
70	0.44
75	0.31
80	0

The current rating are based on ambient temperature 30°C and 1cable in air.
The current rating are in accordance with JCS 0168.

Oil resistance and Solvent resistance

	Gasoline	Heavy oil	Silicone oil	Methanol	Ethanol	Acetone	Benzene	Glycerin	Sulphuric acid		Nitric acid		Hydrochloric acid		Acetic acid	Chlorine gas	Ozone
									Conc.	10%	Conc.	10%	Conc.	10%			
Polyvinyl chloride (PVC)	○	○	○	△	○	×	△	○	△	○	△	△	△	○	△	×	○
Crosslinked polyethylene (XLPE)	○	△	◎	◎	◎	◎	△	◎	△	○	△	○	◎	◎	○	×	◎
Chloroprene rubber (CR)	△	×	◎	◎	◎	○	×	◎	×	○	×	×	△	○	○	×	○

◎ : Suitable for use, ○ : no practical problem, △ : Careful to use, × : Unsuitable for use,

SUMITOMO ELECTRIC INDUSTRIES, LTD.

HEAD OFFICE | Sumitomo Electric Industries, LTD.
TEL: +(81)-3-6406-2663

INDIA | SEI Trading India Pvt. Ltd.
TEL: +(91)-124-4577470

INDONESIA | PT. Sumi Indo Kabel Tbk.
TEL: +(62)21-592-2404

MYANMAR | Sumitomo Electric (Thailand) Ltd. Yangon Branch
TEL: +(95)-97-8820-5567

PHILIPPINES | SEI (Philippines) Incorporated
TEL: +(63)2-811-2755-56

SINGAPORE | Sumitomo Electric Asia Pacific Pte. Ltd
TEL: +(65)6261-3388

THAILAND | Sumitomo Electric (Thailand) Ltd.
TEL: +(66)-2-260-7231-5



Traveling Cable

Traveling Cable

Traveling cable withstands mechanical stresses such as bending and torsion during operation. Therefore traveling cable is heavy duty power and control cable for use on civil works and industrial machines where there are bending, torsional, abrasion and tensile stresses. Moreover special specification such as shielded, flame-retardant, flat type and medium voltage may be applicable in customer's request. Additionally, considering environment, Low smoke zero halogen (LSZH) traveling cable has been developed.

What's for Traveling Cable

- ① Temporary power supply for civil works
- ② Industrial machines (e.g. Hoist, Lifting magnet)
- ③ Harbor facilities (e.g. Gantry Crane)
- ④ Civil machines (e.g. Tunneling Machine)
- ⑤ Submersible pump, Drainage facilities



Type of Application

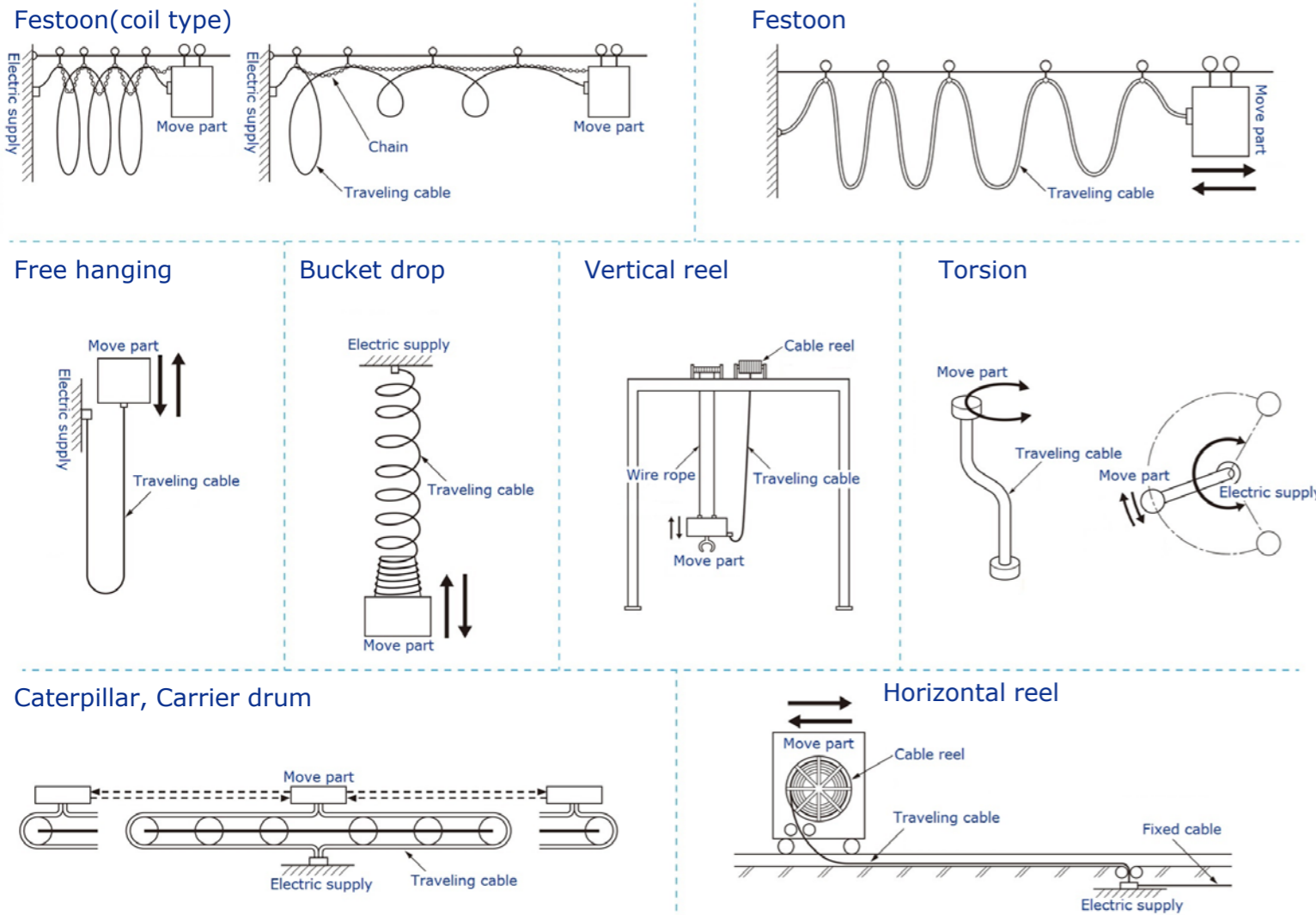

F-TYPE traveling cable

F-TYPE traveling cable has been developed for the use of large-scale industrial machines where there are harsh mechanical stresses and frequent bending, torsional, abrasion and tensile stress during operation. F-TYPE traveling cable is designed for heavy duty use. Thanks to colored tape, filler and short pitch of stranding, F-TYPE is superior in bending-resistance and torsion-resistance.

Type	2PNCT	3PNCT	F-2PNCT	F-2PNCT-R
Construction	<ul style="list-style-type: none"> Conductor Insulation Sheath 	<ul style="list-style-type: none"> Conductor Insulation Sheath Reinforced layer 	<ul style="list-style-type: none"> Conductor Insulation Colored tape Filler Binding tape Sheath 	<ul style="list-style-type: none"> Conductor Insulation Colored tape Filler Binding tape Reinforced layer Sheath
Feature & Application	<ul style="list-style-type: none"> General use such as temporary wiring 	<ul style="list-style-type: none"> With reinforced layer, it superior in clash, abrasion and scratches. Used in where ambient conditions are harsh. 	<ul style="list-style-type: none"> With filler, it tolerate frequent bending and torsion. Used with festoon and torsional application etc. 	<ul style="list-style-type: none"> With filler and reinforced layer, it's superior in clash, scratches, bending and torsion. Used with horizontal reel and carrier drum applications etc.

Special specification

Special spec.	Application	Feature
Rubber filler	When there are harsh squeeze stresses.(i.e. vertical reel)	With rubber as filler, it is hard to buckle.
Conductor with steel wire	When there are over 19.6N/mm ² tensile stresses on conductors. (Contact us when there are over 29.4N/mm ² tensile stresses.)	With stranding steel wire in conductor, it is superior in tensile-resistance.
Bend-retardance	When there are harsh bending stresses.(high speed festoon [>100m/min]) (Don't use when there are torsional stresses.)	With shorter pitch of stranding, it is superior in bend-resistance.
Torsion-retardance	When there are harsh torsional stress.(i.e. Bucket drop)	With anti-torsion braid on stranded cores, it is superior in torsion-resistance.

Flame-retardant traveling cable (SF-2PNCT)

Flame-retardant traveling cable shall pass the flame retardant test in accordance with IEEE Std. 383:1974 (Vertical Open Tray Flame Test). The types of flame-retardant traveling cable are SF-2PNCT, SF-3PNCT, SF-F-2PNCT and SF-F-2PNCT-R.



Construction table (600V 2PNCT)

Referenced Standard: JIS C 3327

Rating Voltage : 600V

Flame retardance : JIS C 3005 horizontal test

Test voltage : AC 3000V · 1minute

Max. operating temperature of conductor: 80°C

Max. short-circuit temperature of conductor: 230°C

Min. bending radius: 6×D (single core, fixed)
4×D (multi core, fixed)
10×D (moving installation)
D = Overall diameter of cable

Allowed tensile stress of conductor: 19.8N/mm²

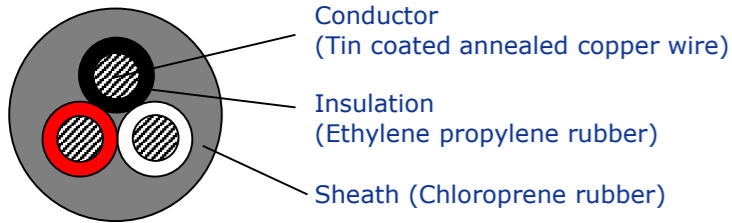

Conductor	Nominal cross-section	mm ²	0.75	1.25	2	3.5	5.5	8	14	22	38	60	100	150	200	250	325	
	Construction	No./mm	30/0.18	50/0.18	37/0.26	45/0.32	70/0.32	50/0.45	88/0.45	7/20/0.45	7/34/0.45	19/20/0.45	19/34/0.45	27/34/0.45	37/34/0.45	37/42/0.45	37/55/0.45	
	Approx. diameter	mm	1.1	1.5	1.8	2.5	3.1	3.7	4.9	6.7	8.7	11.2	14.6	17.4	20.4	22.1	26.0	
Nominal thick. of insulation		mm	0.8	0.8	0.8	0.8	1.0	1.0	1.0	1.2	1.2	1.5	2.0	2.0	2.5	2.5	2.5	
Single-core	Nominal thick. of sheath	mm	1.5	1.5	1.5	1.6	1.6	1.7	1.8	1.9	2.0	2.3	2.6	2.7	3.0	3.1	3.4	
	Approx. overall dia.	mm	5.8	6.2	6.5	7.4	8.4	9.2	11.0	13.0	15.5	19.0	24	27	32	34	38	
	Approx. net weight	kg/km	45	55	65	90	125	160	235	360	545	845	1390	1870	2560	3050	3930	
2-core	Nominal thick. of sheath	mm	1.7	1.7	1.8	1.9	2.0	2.1	2.2	2.5	2.8	3.2	3.8	4.2	4.7	4.9	Contact us	
	Approx. overall dia.	mm	9.0	9.8	10.5	12.5	14.5	16.0	18.5	24	28	35	45	52	61	65		
	Approx. net weight	kg/km	110	135	160	230	330	415	605	975	1490	2320	3870	5210	7170	8450		
3-core	Nominal thick. of sheath	mm	1.7	1.8	1.8	1.9	2.0	2.1	2.3	2.6	2.9	3.4	4.0	4.4	5.0	Contact us		
	Approx. overall dia.	mm	9.4	10.5	11.5	13.0	15.5	17.0	20.0	25	30	38	49	56	65			
	Approx. net weight	kg/km	125	160	190	275	395	500	760	1230	1890	2960	4940	6670	9210			
4-core	Nominal thick. of sheath	mm	1.7	1.8	1.9	2.0	2.1	2.2	2.4	2.8	3.1	3.6	4.3	4.8	Contact us			
	Approx. overall dia.	mm	10.5	11.5	12.5	14.5	17.0	18.5	22	28	34	42	54	62				
	Approx. net weight	kg/km	145	190	235	340	495	625	950	1550	2380	3740	6260	8530				
Max. conductor resistance at 20°C		Ω/km	Single core	25.8	15.5	9.91	5.38	3.46	2.45	1.39	0.892	0.525	0.329	0.193	0.136	0.0993	0.0803	0.0614
			Multi core	26.6	16.0	10.2	5.54	3.56	2.52	1.43	0.919	0.541	0.339	0.199	0.140	0.102	0.0827	0.0632
Min. insulation resistance at 20°C			MΩ · km	500	500	500	400	400	400	300	300	200	200	200	200	200	200	

Construction table (600V 3PNCT)

Referenced Standard: JIS C 3327

Rating Voltage : 600V

Flame retardance : JIS C 3005 horizontal test

Test voltage : AC 3000V · 1minute

Max. operating temperature of conductor: 80°C

Max. short-circuit temperature of conductor: 230°C

Min. bending radius: 6×D (single core, fixed)
4×D (multi core, fixed)
10×D (moving installation)
D = Overall diameter of cable

Allowed tensile stress of conductor: 19.8N/mm²

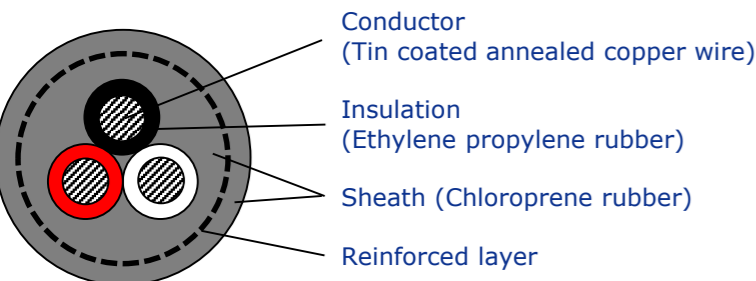

Conductor	Nominal cross-section	mm ²	2	3.5	5.5	8	14	22	38	60	100	150	200	250	325	
	Construction	No./mm	37/0.26	45/0.32	70/0.32	50/0.45	88/0.45	7/20/0.45	7/34/0.45	19/20/0.45	19/34/0.45	27/34/0.45	37/34/0.45	37/42/0.45	37/55/0.45	
	Approx. diameter	mm	1.8	2.5	3.1	3.7	4.9	6.7	8.7	11.2	14.6	17.4	20.4	22.1	26.0	
Nominal thick. of insulation		mm	1.2	1.2	1.2	1.2	1.2	1.6	1.6	2.1	2.1	2.7	3.3	3.3	3.3	
Single-core	Nominal thick. of sheath	mm	2.5	2.5	2.6	2.6	2.7	2.9	3.0	3.2	3.5	3.7	4.0	4.1	4.3	
	Approx. overall dia.	mm	10.5	11.0	12.0	12.5	14.0	17.0	19.5	24	27	32	37	39	43	
	Approx. net weight	kg/km	140	165	200	230	320	485	695	1050	1560	2170	2910	3430	4330	
2-core	Nominal thick. of sheath	mm	2.8	2.9	2.9	3.0	3.2	3.5	3.8	4.3	4.7	5.3	Contact us			
	Approx. overall dia.	mm	15.0	17.0	18.5	19.5	23	29	34	42	50	59				
	Approx. net weight	kg/km	295	380	465	560	815	1290	1850	2840	4240	5980				
3-core	Nominal thick. of sheath	mm	2.8	2.9	3.0	3.1	3.3	3.6	3.9	4.4	4.9	5.5	Contact us			
	Approx. overall dia.	mm	16.0	18.0	19.5	21	25	31	36	44	53	62				
	Approx. net weight	kg/km	340	445	550	660	990	1560	2280	3520	5330	7540				
4-core	Nominal thick. of sheath	mm	2.9	3.0	3.1	3.2	3.4	3.8	4.1	4.7	5.2	Contact us				
	Approx. overall dia.	mm	17.0	19.5	21	23	27	34	39	49	58					
	Approx. net weight	kg/km	390	530	660	810	1210	1930	2840	4410	6720					
Max. conductor resistance at 20°C		Ω/km	Single core	9.91	5.38	3.46	2.45	1.39	0.892	0.525	0.329	0.193	0.136	0.0993	0.0803	0.0614
			Multi core	10.2	5.54	3.56	2.52	1.43	0.919	0.541	0.339	0.199	0.140	0.102	0.0827	0.0632
Min. insulation resistance at 20°C			MΩ · km	500	500	500	400	400	300	300	300	200	300	300	300	200

Other size and other number of cores may be applicable in customer's request. Cable with braid shield may be applicable.

Construction table (600V F-2PNCT)

Referenced Standard: JIS C 3327

Rating Voltage : 600V

Flame retardance : JIS C 3005 horizontal test

Test voltage : AC 3000V · 1minute

Max. operating temperature of conductor: 80°C

Max. short-circuit temperature of conductor: 230°C

Min. bending radius: 10×D (moving installation)
15×D (frequent moving installation)
D = Overall diameter of cable

Allowed tensile stress of conductor: 19.8N/mm²

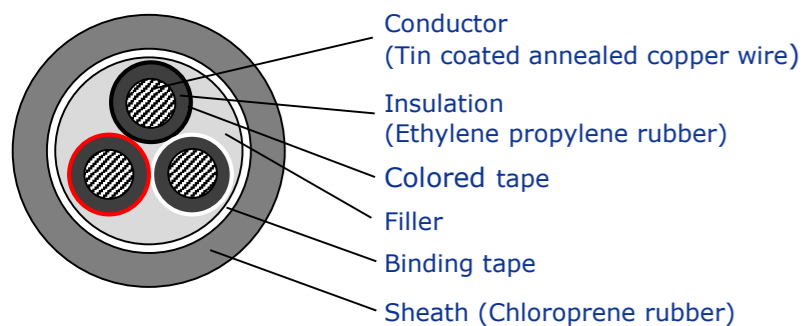

Conductor	Nominal cross-section mm ²	0.75	1.25	2	3.5	5.5	8	14	22	38	60	100	150	200	250	325		
	Construction No./mm	30/0.18	50/0.18	37/0.26	45/0.32	70/0.32	50/0.45	88/0.45	7/20/0.45	7/34/0.45	19/20/0.45	19/34/0.45	27/34/0.45	37/34/0.45	37/42/0.45	37/55/0.45		
	Approx. diameter mm	1.1	1.5	1.8	2.5	3.1	3.7	4.9	6.7	8.7	11.2	14.6	17.4	20.4	22.1	26.0		
Nominal thick. of insulation mm		0.8	0.8	0.8	0.8	1.0	1.0	1.0	1.2	1.2	1.5	2.0	2.0	2.5	2.5	2.5		
2-core	Nominal thick. of sheath mm	1.7	1.8	1.8	1.9	2.0	2.1	2.3	2.6	2.8	3.2	3.8	4.2	4.8	5.0	Contact us		
	Approx. overall dia. mm	10.0	10.5	11.5	13.0	15.0	16.5	19.5	25	29	36	46	52	62	66			
	Approx. net weight kg/km	110	135	160	220	310	385	570	900	1350	2090	3460	4660	6430	7610			
3-core	Nominal thick. of sheath mm	1.7	1.8	1.8	1.9	2.1	2.2	2.3	2.7	3.0	3.4	4.0	4.4	5.0	Contact us			
	Approx. overall dia. mm	10.0	11.5	12.0	13.5	16.0	17.5	21	26	31	39	49	56	66				
	Approx. net weight kg/km	125	160	190	270	395	495	735	1190	1820	2810	4670	6310	8670				
4-core	Nominal thick. of sheath mm	1.8	1.9	1.9	2.0	2.2	2.3	2.5	2.8	3.1	3.6	4.4	4.8	Contact us				
	Approx. overall dia. Mm	11.0	12.5	13.0	15.0	18.0	19.5	23	29	34	43	55	63					
	Approx. net weight kg/km	155	195	235	340	495	625	950	1510	2320	3620	6070	8740					
Max. conductor resistance at 20°C Ω/km		Multi core		26.8	16.1	10.3	5.60	3.60	2.55	1.45	0.928	0.546	0.342	0.201	0.141	0.103	0.0835	0.0639
Min. insulation resistance at 20°C MΩ · km		500	500	500	400	400	400	300	300	200	200	200	200	200	200	200	200	200

Construction table (600V F-2PNCT-R)

Referenced Standard: JIS C 3327

Rating Voltage : 600V

Flame retardance : JIS C 3005 horizontal test

Test voltage : AC 3000V · 1minute

Max. operating temperature of conductor: 80°C

Max. short-circuit temperature of conductor: 230°C

Min. bending radius: 10×D (moving installation)
15×D (frequent moving installation)
D = Overall diameter of cable

Allowed tensile stress of conductor: 19.8N/mm²

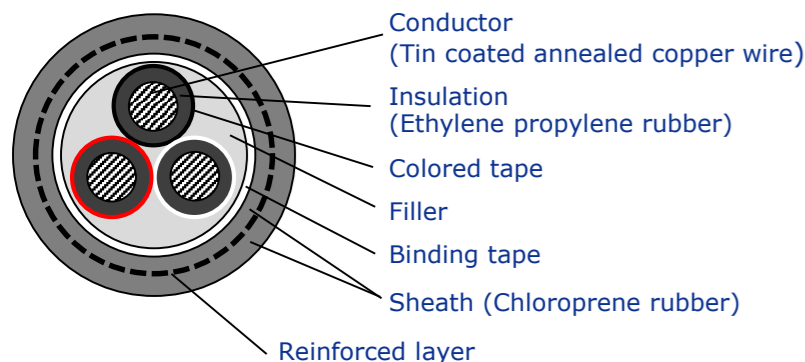

Conductor	Nominal cross-section mm ²	0.75	1.25	2	3.5	5.5	8	14	22	38	60	100	150	200	250	325		
	Construction No./mm	30/0.18	50/0.18	37/0.26	45/0.32	70/0.32	50/0.45	88/0.45	7/20/0.45	7/34/0.45	19/20/0.45	19/34/0.45	27/34/0.45	37/34/0.45	37/42/0.45	37/55/0.45		
	Approx. diameter mm	1.1	1.5	1.8	2.5	3.1	3.7	4.9	6.7	8.7	11.2	14.6	17.4	20.4	22.1	26.0		
Nominal thick. of insulation mm		0.8	0.8	0.8	0.8	1.0	1.0	1.0	1.2	1.2	1.5	2.0	2.0	2.5	2.5	2.5		
2-core	Nominal thick. of sheath mm	2.6	2.7	2.7	2.8	2.9	3.0	3.2	3.5	3.7	4.1	4.7	5.1	Contact us				
	Approx. overall dia. mm	12.5	13.5	14.0	16.0	18.0	19.5	23	28	33	40	50	56					
	Approx. net weight kg/km	180	210	245	315	420	505	740	1110	1600	2390	3850	5100					
3-core	Nominal thick. of sheath mm	2.6	2.7	2.7	2.8	3.0	3.1	3.2	3.6	3.9	4.3	4.9	5.3	Contact us				
	Approx. overall dia. mm	13.0	14.0	15.0	16.5	19.0	21	24	30	35	42	53	60					
	Approx. net weight kg/km	205	240	280	375	505	615	920	1420	2090	3140	5080	6790					
4-core	Nominal thick. of sheath mm	2.7	2.8	2.8	2.9	3.1	3.2	3.4	3.7	4.0	4.5	5.3	Contact us					
	Approx. overall dia. Mm	14.0	15.0	16.0	18.0	21	22	27	32	38	46	59						
	Approx. net weight kg/km	230	280	335	450	615	760	1150	1760	2620	3980	6530						
Max. conductor resistance at 20°C Ω/km		Multi core		26.8	16.1	10.3	5.60	3.60	2.55	1.45	0.928	0.546	0.342	0.201	0.141	0.103	0.0835	0.0639
Min. insulation resistance at 20°C MΩ · km		500	500	500	400	400	400	300	300	200	200	200	200	200	200	200	200	200

Other size and other number of cores may be applicable in customer's request. Cable with braid shield may be applicable.