



Optical Repeater Device Corresponding to 25 Gbps Speed

Toshirou WATANABE, Makoto IIDA, Kiyoshi YAMAUCHI,
and Haruki YONEDA

In the construction of 5th generation (5G) mobile communication systems, the transmission speed at the mobile fronthaul (MFH) section is about 2.5 times faster than that of conventional systems. As the signal speed increases, there is a problem of shortening the optical transmission distance due to the effect of wavelength dispersion in single-mode fibers. As a measure to extend the optical transmission distance, we have developed a media converter type optical repeater that converts the wavelength to the 1.3 μm band, where the effect of wavelength dispersion is minimized. The repeater combines waveform generation processing with electric circuits to compensate the transmission characteristics and can be applied to transmission lines up to 30 km. This paper describes the 25 Gbps optical repeater.

Keywords: 5G, mobile fronthaul, optical wavelength selection, 3R function

1. Introduction

We have been developing and manufacturing optical concentrators*¹ used in the construction of 4th generation (4G) mobile fronthaul (MFH)*² (Fig. 1). When adopting this MFH for 5th generation (5G) mobile communication systems, the tolerance to waveform distortion becomes smaller as the transmission speed increases, and this becomes a major obstacle when constructing MFH. For example, when a 5G antenna is to be installed in the same location as the 4G antenna, the MFH transmission distance becomes too long to install a 5G antenna, which may require a new radio repeater. When signals are transmitted over the same transmission distance, using the same optical fiber, it is the wavelength dispersion*³ of the single-mode fiber that is significantly affected. In general, the transmission penalty due to wavelength dispersion is proportional to the distance and to the square of the transmission speed.⁽¹⁾ Specifically, the maximum transmission speed of 5G systems is 25.7 Gbps, which is approximately 2.5 times faster than that of 4G systems at 9.8 Gbps; therefore, the penalty in 5G systems due to wavelength dispersion is

approximately 6.25 times greater than that in 4G systems. To solve this problem, we have developed an optical repeater corresponding to 25 Gbps transmission that enables the installation of 5G antennas in the same locations as for 4G systems by extending the transmission distance of 25.7 Gbps signals.

2. Basic Concept

The basic concept of the developed product is as follows.

(1) [Near zero-dispersion wavelengths, which are advantageous for long-distance transmission, are used.]

Single-mode fibers are generally used in the MFH section, and wavelength dispersion makes long-distance transmission difficult in the CWDM*⁴ wavelengths, which have been conventionally used. Therefore, near zero-dispersion wavelengths, which are favorable for long-distance transmission, are used.

(2) [Maximum transmission distance of 30 km and allowable transmission loss of 22 dB are ensured at 25.7 Gbps.]

To improve the maximum transmission distance to 30 km and the allowable transmission loss to 22 dB at the relevant transmission speed, the addition of the 3R function corresponding to that transmission speed is considered effective. 3R is a transmission method in which signals are regenerated, reshaped, and retimed. This function is introduced into the repeater.

(3) [Also corresponding to 4G signal transmission]

By using a small form-factor pluggable (SFP) applicable to the transmission speed to be communicated, this product is capable of corresponding not only 5G systems (eCPRI*⁵ signals) but also 4G systems (CPRI*⁶ signals).

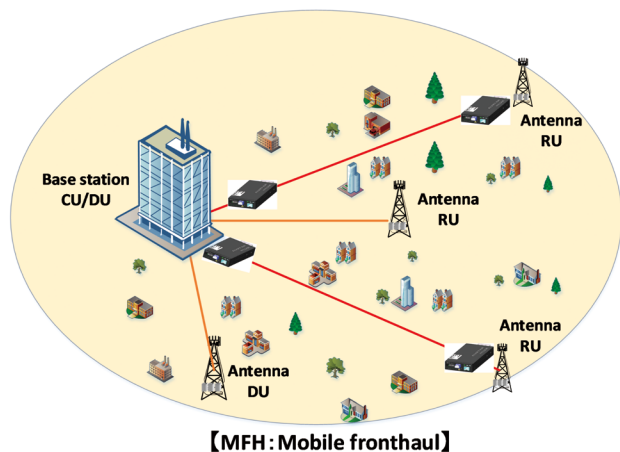

Fig. 1. Mobile fronthaul base station deployment

3. Configuration of Optical Repeater Corresponding to 25 Gbps Transmission

Figures 2 through 4 show the external views of the optical repeater corresponding to 25 Gbps transmission, Tables 1 through 3 show its specifications, and Fig. 5 shows its block diagram. Each unit has one port into which an SFP applicable to the transmission speed when communicating can be inserted and one WDM*7 port (SC) that enables single-fiber bidirectional communication. One unit (SREP25-B) is used on the base station side and one (SREP25-R) on the antenna side in opposite directions and they are connected with a single-fiber single-mode cable.

The power input section is configured to allow selection between DC power supply type (-48 V) and AC power supply type (100 V/200 V) according to the power supply environment used.

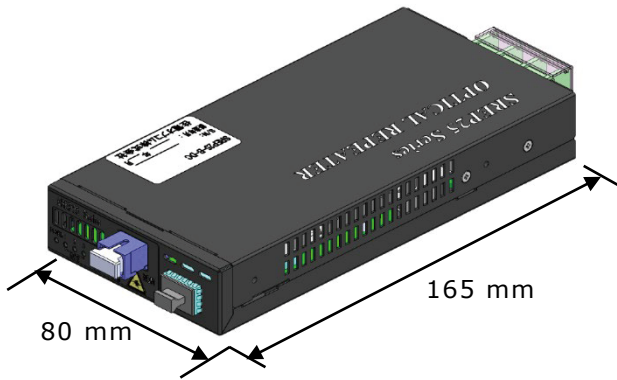

Fig. 2. External view of the device

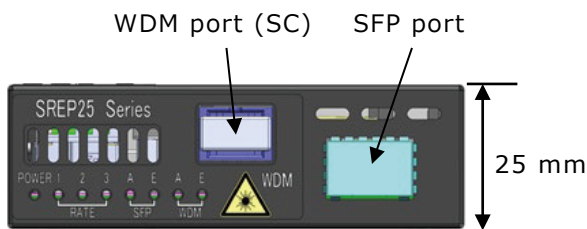

Fig. 3. Front view of the device

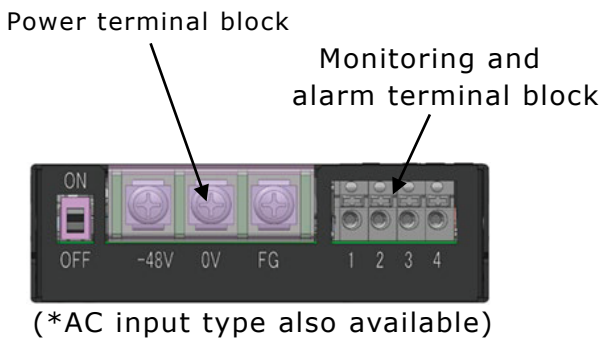

Fig. 4. Rear view of the device

Table 1. Specifications (main unit)

Item	Specification
Operating temperature range	0°C ~ 50°C
Operating humidity range	65% ± 20%RH (No condensation)
Supply voltage	DC: -48 V (-40.5 ~ -57.0 V) AC: 100 V / 200 V
Number of channels	1
Cooling method	Natural air cooling
Monitoring function	Communication failure: Reception level failure Unit failure: SFP failure, unit failure
Outer dimensions	W(80) × D(165) × H(25) mm
Mass	0.5 kg max.
Power consumption	7 W max.

Table 2. eCPRI/CPRI interface specifications

Item	Specification
eCPRI bit rate	① 25.78125 / 10.3125 Gbps
CPRI bit rate	② 9.8304 / 4.9152 Gbps
	③ 2.4576 Gbps
eCPRI optical input	Depends on the SFP to be used
CPRI optical input	
eCPRI optical output	
CPRI optical output	
Optical wavelength	

Table 3. WDM interface specifications

Item	Specification
WDM bit rate	25.78125 / 10.3125 / 9.8304 / 4.9152 / 2.4576 Gbps (Transmission data rate is automatically determined depending on the SFP to be used.)
Wavelength	Upstream: 1300.05 nm Downstream: 1304.58 nm
Allowable transmission loss	22 dB max
Transmission distance	30 km max.

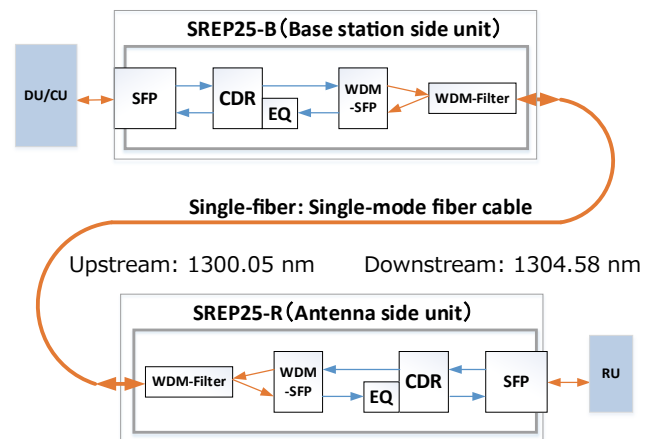

Fig. 5. Block diagram

4. Characteristics of Optical Repeater Corresponding to 25 Gbps Transmission

4-1 Optical wavelength selection

As for the wavelengths to be used, we focused on LAN-WDM*⁸ wavelengths in the 1.3 μm band, which have been increasing in production volume in recent years and are relatively inexpensive and readily available, and selected two wavelengths of 1300.05 and 1304.58 nm, which are near the zero-dispersion wavelength (Fig. 6). We evaluated the characteristics after single-mode fiber transmission at these wavelengths using the measurement system shown in Fig. 7.

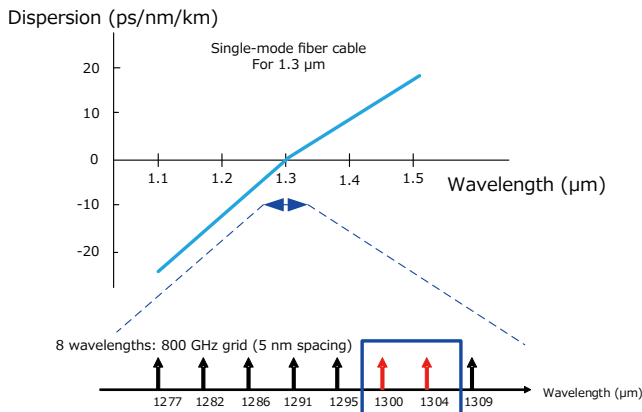

Fig. 6. Selection of wavelength not affected by dispersion characteristics

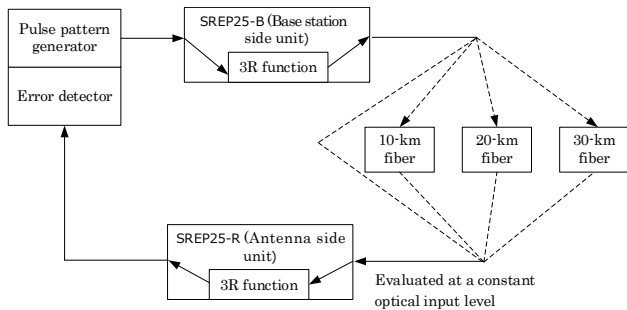

Fig. 7. Measurement system for error rate on selected wavelength distance

The change in error rate when the transmission distance is changed is shown in Fig. 8. The change in error rate with distance is almost zero, confirming that it is not affected by wavelength dispersion.

4-2 3R function

We equipped the unit with the 3R function to secure allowable transmission loss of 22 dB at a transmission speed of 25.7 Gbps. Using the measurement systems shown in Figs. 9 and 10, we conducted a comparative evaluation of transmission characteristics when transmitting signals 30 km with and without the 3R function.

In the measurement, we used the error rate*⁹ of 5.0E-05 at which transmission is error-free when forward error correction (FEC)*¹⁰ is enabled as the standard for evaluation.

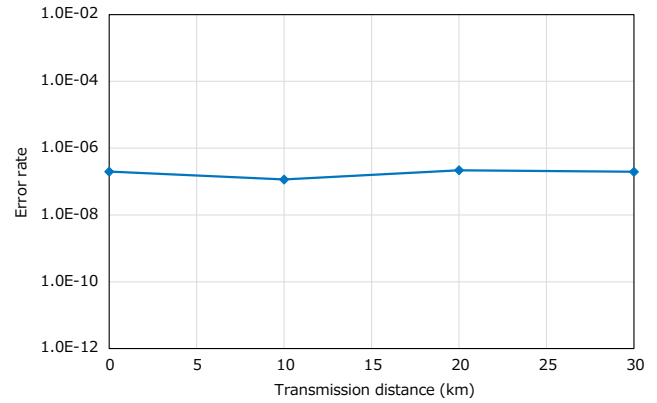

Fig. 8. Error rate on selected wavelength distance

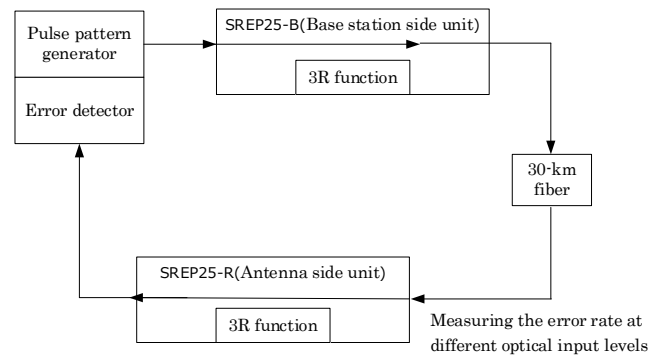

Fig. 9. Measurement system without 3R function

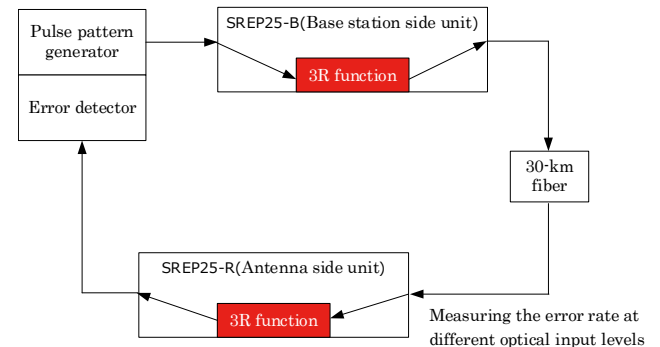

Fig. 10. Measurement system with 3R function

Figure 11 indicates the evaluation results.

Without the 3R function, the error rate increased significantly and exceeded the standard, 5.0E-05. On the other hand, with the 3R function, the error rate is 5.0E-05 at -22.6 dBm, which is 0.6 dB less than the product standard of -22 dBm, enabling long-distance transmission over 30 km.

4-3 Reliability tests

The results of the reliability test items shown in Table 4 were all favorable, confirming that the device is reliable enough for practical use.

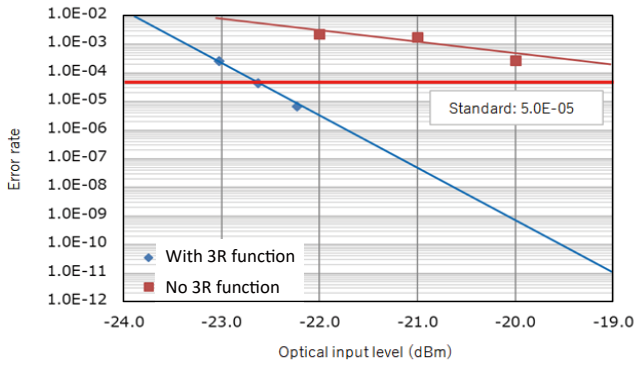

Fig. 11. Receiving sensitivity characteristics at a transmission distance of 30 km

Table 4. Reliability test items and results

No.	Test item	Conditions	Judgment
1	High temperature test	(1) Temperature: +70°C, storage time: 72 hours, not energized (2) Temperature: +55°C, energization time: 96 hours, energized	Favorable
2	Low-temperature test	(1) Temperature: +20°C, storage time: 72 hours, not energized (2) Temperature: -5°C, energization time: 96 hours, energized	Favorable
3	Temperature cycling test	Temperature: -15°C to 55°C, number of cycles: 5, energized	Favorable
4	Static charge tolerance test	Contact: ±4 kV. Air: Application of voltage of ±8 kV to various parts of the unit	Favorable
5	Lightning surge test	Application of combination voltage waveform of ±0.5 kV to each port of L1, L2, and PE 5 times (1 minute interval)	Favorable
6	Radiated/conducted Emission Test	Class A of the VCCI Technical Standard (VCCI-CISPR32:2016) shall be satisfied.	Favorable
7	Vibration test	Frequency: 10 to 55 Hz, single amplitude: 0.75 mm Vibration time 45 minutes in each direction Vibration directions: X, Y, Z	Favorable
8	Impact test	Impact force: 50 G Impact directions: 3 directions Sine pulse: 11 ms	Favorable

5. Conclusion

This paper introduced the concept of optimum wavelength selection and the addition of 3R function for the optical repeater corresponding to 25 Gbps transmission. This product has enabled a maximum transmission distance of 30 km even at 25 Gbps to expand the options for installing 5G antennas in the same locations as 4G antennas, thereby helping construct 5G systems. We will continue to develop technologies and products that facilitate the construction of 5G MFH.

Technical Terms

- *1 Optical concentrator: A device that enables transmission of multiple optical fiber transmission signals on a single optical fiber by wavelength-division multiplexing.
- *2 Mobile fronthaul: The line between the baseband processing section of the base station unit and the radio unit in mobile communications.
- *3 Wavelength dispersion: A phenomenon in which light of different wavelengths propagates through an optical fiber at different speeds, causing a difference in propagation time = delay.

- *4 CWDM: A type of wavelength division multiplexing (WDM) technology for increasing the transmission density of an optical fiber, and a communication method with low wavelength density.
- *5 eCPRI (Evolved CPRI): An Ethernet-based communication standard used for communication between a radio base station and an antenna section.
- *6 CPRI (Common public radio interface): A communication standard used for communication between a radio base station and an antenna section, based on digital sampling of analog signals.
- *7 WDM (Wavelength division multiplexing): A multiplexing technology for simultaneously transmitting and receiving signals and data from multiple lines on a single line, using multiple optical signals of different wavelengths on an optical fiber line or other lines.
- *8 LAN-WDM: A method of wavelength division multiplexing in the 1.3 μm band with a wavelength spacing of approximately 5 μm (800 GHz) into four wavelengths: 1295.56 nm, 1300.05 nm, 1304.58 nm, and 1309.14 nm. Compared to DWDM, which has a spacing of about 0.4 nm (50 GHz), the wavelength spacing is wider in LAN-WDM, which does not require precise laser temperature adjustment.
- *9 Error rate: The probability of an error occurring in a transmission signal in digital transmission.
- *10 Forward error correction (FEC): A method of error correction for recording, reading, transmitting, and receiving data in which data with a redundant code is sent in advance in anticipation of errors, and the receiver restores the original data.

Reference

- (1) Y. Takizawa, T. Taguchi, and D. Umeda, "Wavelength Division Multiplexing Transmission Method for 5G Radio Access Networks to Achieve 40 km Transmission," SEI TECHNICAL REVIEW, No. 91, pp.44-47 (October 2020)

Contributors The lead author is indicated by an asterisk (*).

T. WATANABE*

• Senior Staff, Sumiden Opcom, Ltd.



M. IIDA

• Sumiden Opcom, Ltd.



K. YAMAUCHI

• Deputy Manager, Sumiden Opcom, Ltd.



H. YONEDA

• Manager, Sumiden Opcom, Ltd.

