

Pre-connectorized Ultra-High-Fiber-Count Cable for Easy Installation

Yutaka HASHIMOTO*, Fumiaki SATO, Satoshi OHNUKI,
Takayuki SHIMAZU, and Kenichiro OHTSUKA

This paper describes a new pre-connectorized ultra-high-fiber-count (UHFC) optical fiber cable that has been developed to reduce installation time in data centers. The cable is made of a thin 3456-fiber optical cable consisting of 200 μm Freeform Ribbon fibers and a slotted core. At both ends of the cable, 24-fiber multi-fiber push-on (MPO) connectors are assembled and precisely sealed with a protection sleeve optimally designed for tensile and other mechanical properties. The result of a cable pulling test simulating actual installation was confirmed that the developed cable achieves the same number of optical fibers accommodated in the duct as conventional non-connectorized cables. This cable enables a reduction of connection time by using the MPO connectors instead of mass fusion splicing, and is expected to reduce installation time by about 40% compared to conventional cables.

Keywords: pre-connectorized 3456-fiber-count cable, 200 μm optical fiber, MPO connector, protection sleeve, cable pulling

1. Introduction

Recently, a growing number of large-scale data centers (DCs) have been constructed around the world, mainly due to the advancement of cloud computing. In order to cope with the increase in transmission capacity, there is a growing demand for higher-density optical fiber cables connecting DCs and lower installation costs.

Cables that connect DCs are usually installed in underground ducts and the duct space is often limited. Therefore, the technology to accommodate optical fibers in a cable at high density is quite important.

Sumitomo Electric Industries, Ltd. developed and commercialized a 6912-fiber-count optical cable in 2017. This optical fiber cable comprised the highest number of fibers in any cable in the world at that time. The company also developed wiring solutions, as shown in Fig. 1, and contributed to increasing wiring density, and improving workability at entire DCs.

To reduce installation time at DCs, we have developed and commercialized a pre-connectorized 3456-fiber-count optical cable at both ends of which multi-fiber connectors are preassembled at plants.

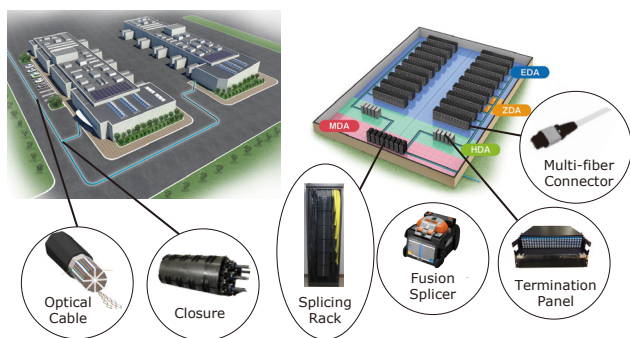

Fig. 1. Schematic diagram of wiring between DC buildings

2. Structure and Characteristics of Optical Fiber Cable

2-1 Design of 200 μm optical fiber

Figure 2 shows a schematic cross-section of the 200 μm optical fiber used for this development. The 200 μm optical fiber saves 36% of cross-sectional area by reducing the cladding thickness, while the glass diameter remains 125 μm as before.

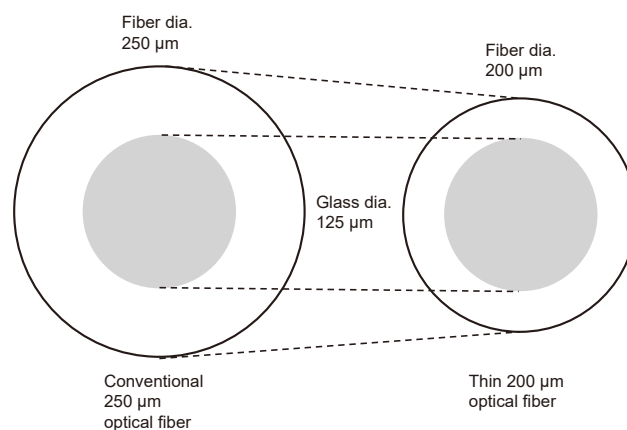

Fig. 2. Schematic cross-section of thin 200 μm optical fiber

2-2 Design of 200 μm Freeform Ribbon

The 200 μm Freeform Ribbon*¹ used for this development is a 12-fiber pliable ribbon. Figure 3 shows the schematic diagram.

The flexibility of the pliable ribbons and ribbon alignment for mass-fusion splicing can be controlled by changing the ratio of slit and non-slit lengths and the slit length itself. This time, the slit and non-slit length ratio has been optimized considering the mass fusion splicing workability and cable characteristics.

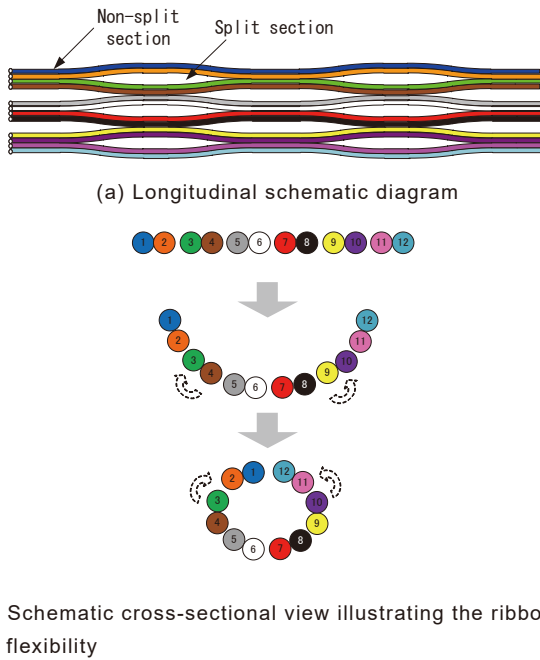

Fig. 3. Schematic diagram of 200 μm 12-fiber Freeform Ribbon

2-3 Structure of small-diameter 3456-fiber-count cable

The slotted core cable structure design has been used this time same with the conventional 250 μm 3456-fiber-count cable, which has no preference in bending direction and high flexibility because of the design that a fiber-reinforced plastic (FRP) strength member*2 is placed at the center of the cable. The optical fibers used in the cable are 200 μm bend-insensitive single-mode fibers (SMFs) (compatible with ITU-T G.657A1 and G.652D specifications) to downsize the 3456-fiber-count cable. Figure 4 shows a schematic cross-section of the 3456-fiber-count cable.

As a result, a significant downsizing has been achieved, reducing the cable cross-sectional area by approximately 32% compared to the conventional 250 μm 3456-core cable.

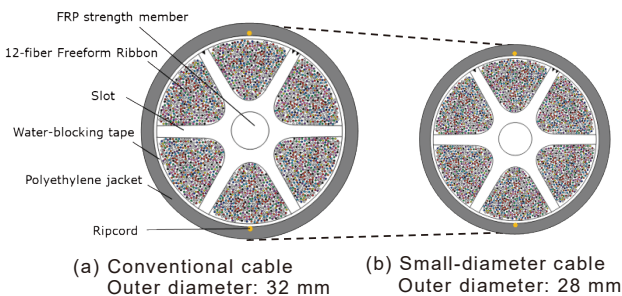

Fig. 4. Schematic cross-section of 3456-fiber-count cables

2-4 Structure of MPO connector

Figure 5 shows an overview of an MPO connector*3 using an MT ferrule as a key component. Fiber-mounted

ferrules with or without guide pins are stored in the MPO housing, and are connected via an adaptor. A compression spring is built into the housing to ensure physical contact with the fiber cores each other.

The end face of an MPO connector for SMFs is polished at angled 8° to minimize the return loss.

The end face of an MT ferrule that determines the characteristics of the MPO connector is illustrated in Fig. 6.

Optical fibers with a glass diameter 0.125 mm are arranged at 0.25 mm intervals between two guide holes with a diameter of 0.7 mm. These guide holes are used as the references for positioning the connector. In the coordinate system based on the centers of both guide holes, the difference between the actual fiber position and the design position is called the “eccentricity”. The connection loss of an MPO connector depends mostly on the axis misalignment of the fibers. The technical key to minimizing the connection loss is reducing “eccentricity”.

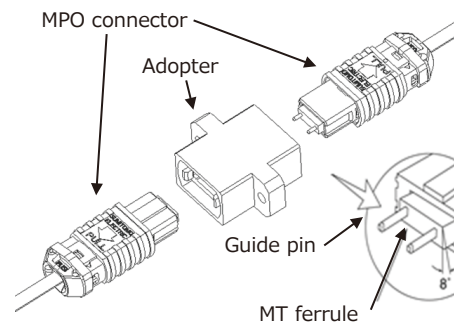

Fig. 5. Overview of MPO connector

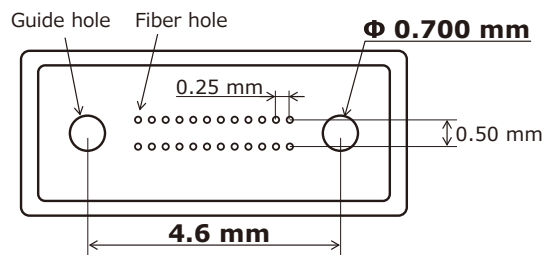

Fig. 6. End face of MT ferrule

2-5 Structure of terminated protection sleeve and connector plugging

Figure 7 shows an overview of the terminals of a pre-connectorized 3456-fiber-count cable, a connector protection sleeve, and an enclosure for connector patching (OPE). The cable is terminated by 144 pcs of 24-fiber MPO connectors and sealed with a protection sleeve with a diameter of 60 mm. To accommodate MPO connectors in the protection sleeve, MPO connectors are assembled in longitudinally shifted positions for every 12 connectors. For ease of installation, the protection sleeve is made of a spiral metal tube with resin coating as they are required to

have the same level of mechanical performance as the cable, such as tensile strength, compressive strength, and waterproofing. This provides both high flexibility and tensile strength. For the connection between the protection tube and cable, a part for connecting the protection tube is crimp-fixed to the cable tension member for ease of removal after installation, and the protection tube is attached to this part. This configuration facilitates the removal of the protective tube after installation. The terminals are plugged into the MPO connectors of indoor cables at an OPE.

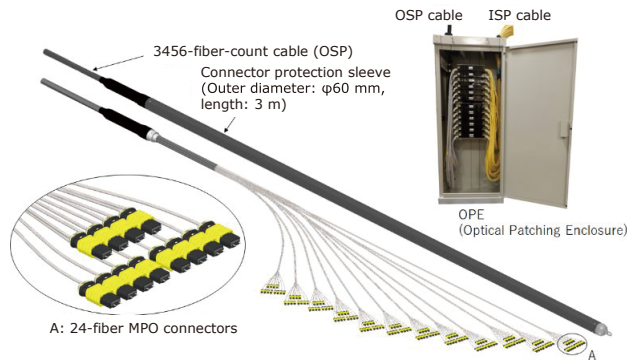

Fig. 7. Overview of pre-connectorized cable terminals and protection sleeve

2-6 Cable characteristics

Table 1 shows the transmission characteristics and mechanical test evaluation results of the pre-connectorized 3456-fiber-count cable and the connector characteristics.

As shown in Table 1, good characteristics were confirmed in the evaluation of various mechanical tests.

Table 1. Results of characteristics evaluation of pre-connectorized 3456-fiber-count cable

Item	Test method	EvaluationResults
Attenuation Coefficient	IEC60793-1-40	< 0.4 dB/km ($\lambda=1310$ nm) < 0.3 dB/km ($\lambda=1550$ nm)
Temperature Cycling	EIA/TIA-455-4 -40/+70°C × 3 cycles, $\lambda=1550$ nm	Maximum Change in Fiber Attenuation Coefficient < 0.10 dB/km
Crush Performance	EIA/TIA-455-41 2200N/100 mm $\lambda=1550$ nm	Maximum Change in Fiber Attenuation < 0.1 dB No visible cracks, splits, tears on the sheath
Impact Performance	EIA/TIA-455-25 4.4 N, 2 drop impacts $\lambda=1550$ nm	
Repeated Bending	EIA/TIA-455-104 Bend radius: 10 × D, 25 cycles (D: cable outer diameter) $\lambda=1550$ nm	
Torsion	EIA/TIA-455-85 ±180°/2 m, $\lambda=1550$ nm	
Tensile Strength	EIA/TIA-455-33 During installation: 2,670 N, after installation: 800 N	Fiber strain with 2,670 N: less than 0.2% Fiber strain with 800 N: 0.1% or less
Connection loss of 24f MPO	$\lambda=1310$ nm	< 0.35 dB
Return loss of 24f MPO	$\lambda=1310$ nm	> 55 dB

3. Installation Workability

3-1 Experiments of pulling into a duct

Using the developed pre-connectorized 3456-fiber-count cable, we conducted experiments of pulling the cable into a duct to check the installation workability. Photo 1 shows the route for the experiments. The duct used in the experiments had an inner diameter of 4 inches. The route had an overall length of 100 m, three 90° curves, and a 180° turn.

The results of the pulling experiments using a conventional 3456-fiber-count cable and a newly developed pre-connectorized 3456-fiber-count cable are shown in Table 2.

We used the developed pre-connectorized 3456-fiber-count cable as the third cable under Condition A, and confirmed that the cable could be installed with a pulling tension equivalent to that required for installing a conventional cable under Condition B.

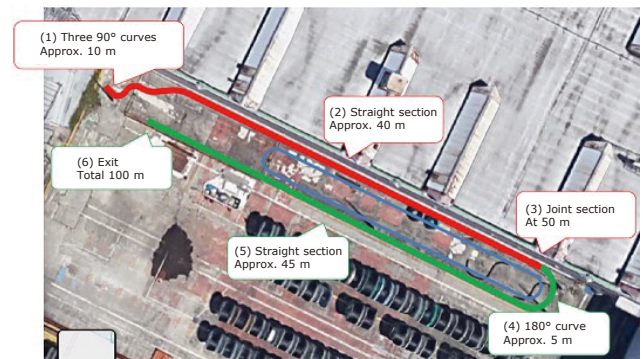

Photo 1. Overview of the route for experiments of pulling a 3456-fiber-count cable into a duct (Map data ©2022 Google)

Table 2. Results of experiments of pulling a 3456-fiber-count cable into a duct

Experiment conditions	Installation cable	Installation result
Condition A: Two conventional 3456-fiber-count cables + One pre-connectorized 3456-fiber-count cable	First cable (Conventional)	Pass (Pulling tension: 9 kg)
	Second cable (Conventional)	Pass (Pulling tension: 12 kg)
	Third cable (Pre-connectorized)	Pass (Pulling tension: 16 kg)
Condition B: Three conventional 3456-fiber-count cables (Reference)	First cable (Conventional)	Pass (Pulling tension: 12 kg)
	Second cable (Conventional)	Pass (Pulling tension: 14 kg)
	Third cable (Conventional)	Pass (Pulling tension: 15 kg)

3-2 Durability evaluation of terminated protection sleeve

To evaluate the durability of the protection sleeve for a pre-connectorized 3456-fiber-count cable, we repeatedly installed a cable into a 4-inch duct and checked the damage to the protection sleeve.

Photo 2 shows the appearance of the protection sleeve after 30 times installations along a 100 m route.

It was confirmed that there was no problem with the durability of the protective tube even under the severe conditions of 30 repeated installations.



Photo 2. Appearance of the protection sleeve for a pre-connectorized small-diameter 3456-fiber-count cable after a durability test

3-3 Comparison of installation days

We estimated the efficiency in the reduction of installation work time when using pre-connectorized 3456-fiber-count cables. Figure 8 shows the results of a comparison of the number of installation days required to complete the connection of three 3456-fiber-count cables through a 4-inch pipe.

As shown in Fig. 8, the use of pre-connectorized 3456-fiber-count cables is expected to drastically reduce the termination time by replacing the fusion splicing with connector plugging. As a result, approx.40% reduction in installation time compared to conventional 3456-fiber-count cables can be expected.

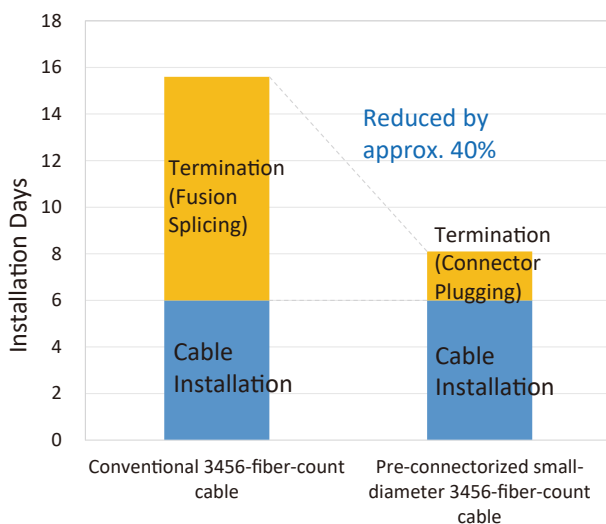

Fig. 8. Comparison of the number of days required for installation of 3456-fiber-count cables

4. Conclusion

We have developed and commercialized a pre-connectorized 3456-fiber-count optical cable with MPO connectors on both ends for DC applications. This cable can save connection time by using connectors instead of time-consuming mass-fusion splicing, and is expected to reduce cable installation time by approximately 40% compared to the use of conventional cables.

Technical Terms

- *1 Freeform Ribbon: A flexible pliable ribbon. Freeform Ribbon is a registered trademark of Sumitomo Electric Industries, Ltd.
- *2 Strength member: A tension member that relieves the tension applied to optical fibers during installation.
- *3 MPO connectors: An abbreviation for multi-fiber push-on connectors. Multi-fiber optical fiber connectors for connecting optical fibers by means of physical contact (PC) connection technology.

References

- (1) F. Sato, et al., "Ultra-High-Fiber-Count and High-Density Slotted Core Cable with Pliable 12-Fiber Ribbons," Proceedings of the 65th IWCS Conference, 2016 (14-5)
- (2) F. Sato, et al., "Designs and Characteristics of New UHFC Cables with Freeform Ribbons," Proceedings of the 67th IWCS Conference, 2018 (10-3)
- (3) F. Sato, et al., "New HFFC cable solution with free form ribbons for easy installation," Proceedings of the 69th IWCS Conference, 2020 (6-2)
- (4) F. Sato, et al., "Ultra-High-Fiber-Count and High-Density Slotted Core Cable with Pliable 12-Fiber Ribbons," SEI TECHNICAL REVIEW, No. 83 (2016)
- (5) F. Sato, et al., "Ultra-High-Fiber-Count Optical Cable for Data Center Applications," SEI TECHNICAL REVIEW, No. 86, pp. 45-50 (2018)
- (6) T. Kamada, et al., "Ultra-Compact MPO Connector with Excellent Handling and Bending Strength," SEI TECHNICAL REVIEW, No. 82 (2016)
- (7) M. Tsuruga, et al., "High-Density Optical Cabling Solution for Data Centers," SEI TECHNICAL REVIEW, No. 86 (2018)

Contributors The lead author is indicated by an asterisk (*).

Y. HASHIMOTO*

- Assistant General Manager, Optical Fiber & Cable Division



F. SATO

- Group Manager, Optical Fiber & Cable Division



S. OHNUKI

- Sumitomo Electric Lightwave, Corp.



T. SHIMAZU

- Senior Assistant General Manager, Lightwave Network Products Division



K. OHTSUKA

- Director, Lightwave Network Products Division

